

SERVICE & OPERATING MANUAL

Original Instructions

Certified Quality



SAI GLOBAL

ISO 9001 Certified
ISO 14001 Certified

Member of
Hydraulic

EAC

Warren Rupp, Inc.
A Unit of IDEX Corporation
800 N. Main St.,
Mansfield, Ohio 44902 USA
Telephone (419) 524.8388
Fax (419) 522.7867
SANDPIPERPUMP.COM



©2017 Warren Rupp, Inc.

SH2-M

Heavy Duty - High Pressure Design Level 7

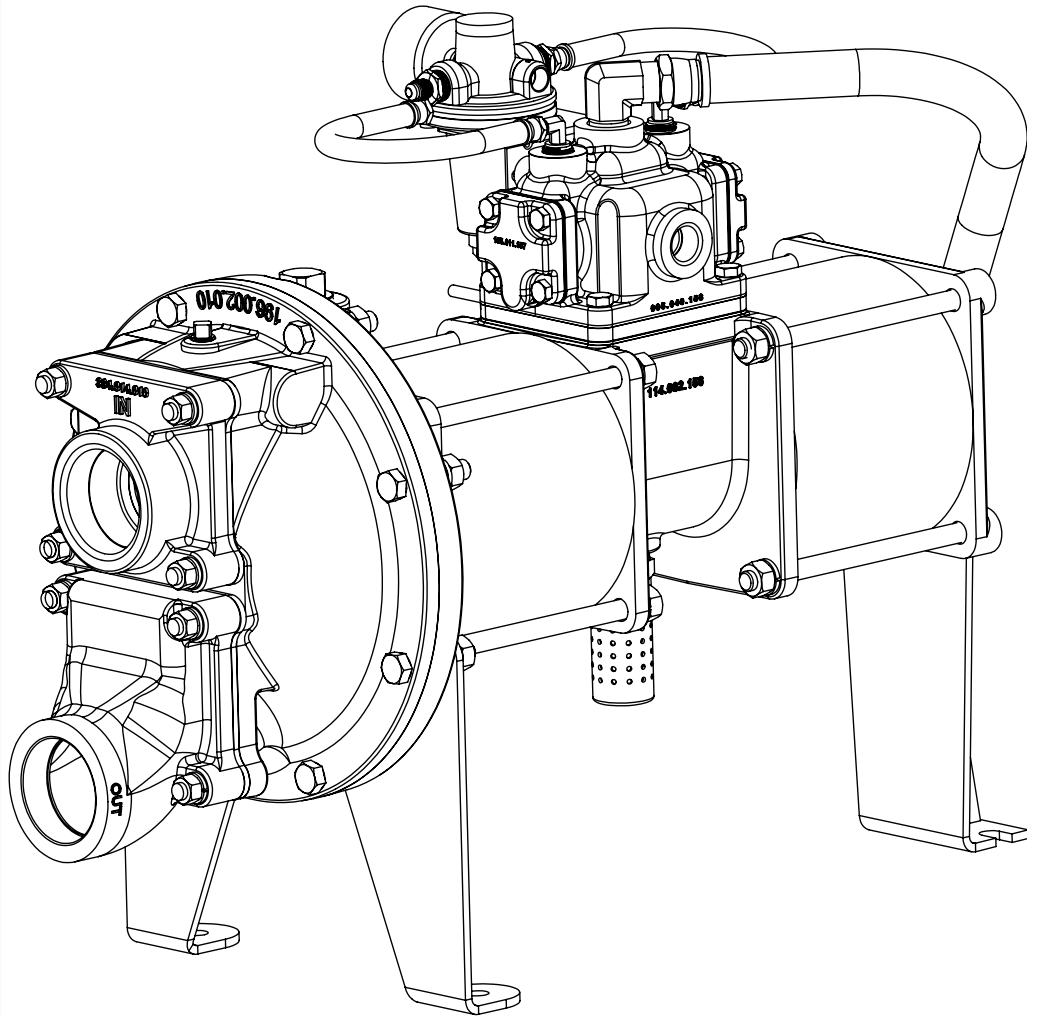

1: PUMP SPECS

2: INSTAL & OP

3: EXP VIEW

4: AIR END

5: WET END

6: OPTIONAL

7: WARRANTY

SANDPIPER[®]
A WARREN RUPP, INC. BRAND

SANDPIPERPUMP.COM

Safety Information

IMPORTANT



Read the safety warnings and instructions in this manual before pump installation and start-up. Failure to comply with the recommendations stated in this manual could damage the pump and void factory warranty.



When the pump is used for materials that tend to settle out or solidify, the pump should be flushed after each use to prevent damage. In freezing temperatures the pump should be completely drained between uses.

CAUTION



Before pump operation, inspect all fasteners for loosening caused by gasket creep. Retighten loose fasteners to prevent leakage. Follow recommended torques stated in this manual.



Nonmetallic pumps and plastic components are not UV stabilized. Ultraviolet radiation can damage these parts and negatively affect material properties. Do not expose to UV light for extended periods of time.



WARNING
The use of non-OEM replacement parts will void (or negate) agency certifications, including CE, ATEX, CSA, 3A and EC1935 compliance (Food Contact Materials). Warren Rupp, Inc. cannot ensure nor warrant non-OEM parts to meet the stringent requirements of the certifying agencies.

RECYCLING

Many components of SANDPIPER® AODD pumps are made of recyclable materials. We encourage pump users to recycle worn out parts and pumps whenever possible, after any hazardous pumped fluids are thoroughly flushed.

WARNING



When used for toxic or aggressive fluids, the pump should always be flushed clean prior to disassembly.



Before maintenance or repair, shut off the compressed air line, bleed the pressure, and disconnect the air line from the pump. Be certain that approved eye protection and protective clothing are worn at all times. Failure to follow these recommendations may result in serious injury or death.



Airborne particles and loud noise hazards. Wear eye and ear protection.



In the event of diaphragm rupture, pumped material may enter the air end of the pump, and be discharged into the atmosphere. If pumping a product that is hazardous or toxic, the air exhaust must be piped to an appropriate area for safe containment.



Take action to prevent static sparking. Fire or explosion can result, especially when handling flammable liquids. The pump, piping, valves, containers and other miscellaneous equipment must be properly grounded.



This pump is pressurized internally with air pressure during operation. Make certain that all fasteners are in good condition and are reinstalled properly during reassembly.



Use safe practices when lifting

Grounding ATEX Pumps

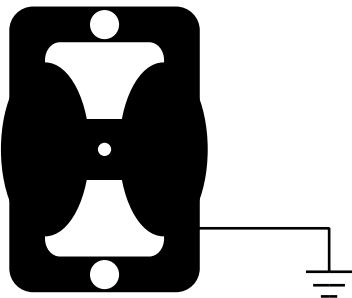

ATEX compliant pumps are suitable for use in explosive atmospheres when the equipment is properly grounded in accordance with local electrical codes. Pumps equipped with electrically conductive diaphragms are suitable for the transfer of conductive or non-conductive fluids of any explosion group. When operating pumps equipped with non-conductive diaphragms that exceed the maximum permissible projected area, as defined in EN 13463-1: 2009 section 6.7.5 table 9, the following protection methods must be applied:

- Equipment is always used to transfer electrically conductive fluids or
- Explosive environment is prevented from entering the internal portions of the pump, i.e. dry running

For further guidance on ATEX applications, please consult the factory.

Table of Contents

SECTION 1: PUMP SPECIFICATIONS.....1

- Explanation of Nomenclature
- Performance
- Materials
- Dimensional Drawings

SECTION 2: INSTALLATION & OPERATION.....5

- Principle of Pump Operation
- Recommended Installation Guide
- Troubleshooting Guide

SECTION 3: EXPLODED VIEW.....8

- Composite Repair Parts Drawing
- Composite Repair Parts List
- Down Ported Option Drawing
- Material Codes

SECTION 4: AIR END.....12

- Air Distribution Valve Assembly
- Pilot Valve Assembly

SECTION 5: WET END14

- Diaphragm Servicing

SECTION 7: WARRANTY & CERTIFICATES15

- Warranty
- CE Declaration of Conformity - Machinery
- ATEX Declaration of Conformity

1: PUMP SPECS

2: INSTAL & OP

3: EXP VIEW

4: AIR END

5: WET END

6: OPTIONAL

7: WARRANTY

Explanation of Pump Nomenclature

Your Model #: _____
 (fill in from pump nameplate)

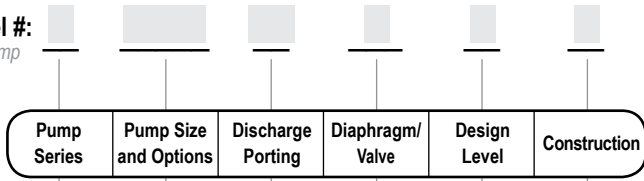

Model #: **XX** **X,** **X** **XX** **X** **X**

Pump Series

SH High Pressure-Flap

Pump Size & Options

2 2"

Discharge Porting Position

D Down

Diaphragm Check Valve Materials

- B Nitrile
- I EPDM
- N Neoprene
- V FKM

Design Level

7

Construction

- A Aluminum
- I Cast Iron

Your Serial #: (fill in from pump nameplate) _____

ATEX Detail

	ATEX Detail	Construction	Options
	II 2G c T5	I,S	N/A
	II 2D c T100°C		

Performance

SH2-M

SUCTION/DISCHARGE PORT SIZE

- SH2-M: 2" NPT

CAPACITY

- 0 to 120 gallons per minute (0 to 454 liters per minute)

AIR DISTRIBUTION VALVE

- No-lube, no-stall design

SOLIDS-HANDLING

- Up to 1.8" in. (46.8 mm)

HEADS UP TO

- 250 psi or 577 ft. of water (17 bar or 176 meters of water)

MAXIMUM OPERATING PRESSURE

- 125 psi (8.6 bar)

DISPLACEMENT/STROKE

- .50 Gallon / 1.8 liter

SHIPPING WEIGHT

- Aluminum 140 lbs. (63 kg)
- Cast Iron 155 lbs. (70 kg)

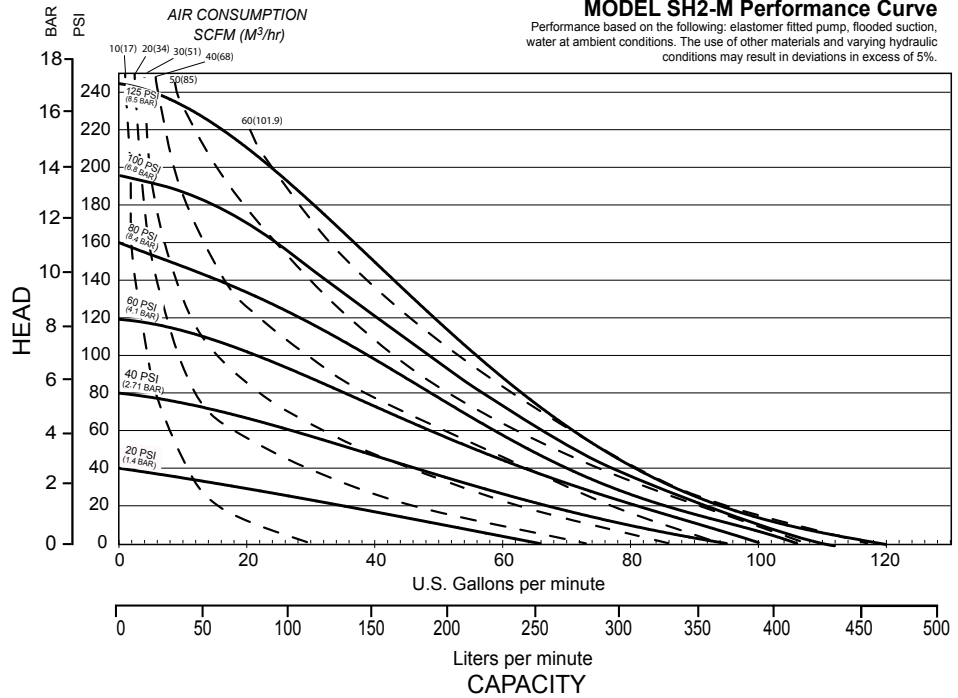

Materials

Material Profile:	Operating Temperatures:	
	Max.	Min.
Conductive Acetal: Tough, impact resistant, ductile. Good abrasion resistance and low friction surface. Generally inert, with good chemical resistance except for strong acids and oxidizing agents.	190°F 88°C	-20°F -29°C
EPDM: Shows very good water and chemical resistance. Has poor resistance to oils and solvents, but is fair in ketones and alcohols.	280°F 138°C	-40°F -40°C
FKM: (Fluorocarbon) Shows good resistance to a wide range of oils and solvents; especially all aliphatic, aromatic and halogenated hydrocarbons, acids, animal and vegetable oils. Hot water or hot aqueous solutions (over 70°F(21°C)) will attack FKM.	350°F 177°C	-40°F -40°C
Hytrel®: Good on acids, bases, amines and glycols at room temperatures only.	220°F 104°C	-20°F -29°C
Neoprene: All purpose. Resistance to vegetable oils. Generally not affected by moderate chemicals, fats, greases and many oils and solvents. Generally attacked by strong oxidizing acids, ketones, esters and nitro hydrocarbons and chlorinated aromatic hydrocarbons.	200°F 93°C	-10°F -23°C
Nitrile: General purpose, oil-resistant. Shows good solvent, oil, water and hydraulic fluid resistance. Should not be used with highly polar solvents like acetone and MEK, ozone, chlorinated hydrocarbons and nitro hydrocarbons.	190°F 88°C	-10°F -23°C
Nylon: 6/6 High strength and toughness over a wide temperature range. Moderate to good resistance to fuels, oils and chemicals.	180°F 82°C	32°F 0°C

- Ambient temperature range:** -20°C to +40°C
Process temperature range: -20°C to +80°C for models rated as category 1 equipment
-20°C to +100°C for models rated as category 2 equipment

In addition, the ambient temperature range and the process temperature range do not exceed the operating temperature range of the applied non-metallic parts as listed in the manuals of the pumps.

Polypropylene: A thermoplastic polymer. Moderate tensile and flex strength. Resists strong acids and alkali. Attacked by chlorine, fuming nitric acid and other strong oxidizing agents.	180°F 82°C	32°F 0°C
PVDF: (Polyvinylidene Fluoride) A durable fluoroplastic with excellent chemical resistance. Excellent for UV applications. High tensile strength and impact resistance.	250°F 121°C	0°F -18°C
Santoprene®: Injection molded thermoplastic elastomer with no fabric layer. Long mechanical flex life. Excellent abrasion resistance.	275°F 135°C	-40°F -40°C
UHMW PE: A thermoplastic that is highly resistant to a broad range of chemicals. Exhibits outstanding abrasion and impact resistance, along with environmental stress-cracking resistance.	180°F 82°C	-35°F -37°C
Urethane: Shows good resistance to abrasives. Has poor resistance to most solvents and oils.	150°F 66°C	32°F 0°C
Virgin PTFE: (PFA/TFE) Chemically inert, virtually impervious. Very few chemicals are known to chemically react with PTFE; molten alkali metals, turbulent liquid or gaseous fluorine and a few fluoro-chemicals such as chlorine trifluoride or oxygen difluoride which readily liberate free fluorine at elevated temperatures.	220°F 104°C	-35°F -37°C

Maximum and Minimum Temperatures are the limits for which these materials can be operated. Temperatures coupled with pressure affect the longevity of diaphragm pump components. Maximum life should not be expected at the extreme limits of the temperature ranges.

Metals:
Alloy C: Equal to ASTM494 CW-12M-1 specification for nickel and nickel alloy.
Stainless Steel: Equal to or exceeding ASTM specification A743 CF-8M for corrosion resistant iron chromium, iron chromium nickel and nickel based alloy castings for general applications. Commonly referred to as 316 Stainless Steel in the pump industry.

For specific applications, always consult the Chemical Resistance Chart.

Dimensional Drawings

SH2-M, Cast Iron Wetted

Dimensions are $\pm .13"$ (3mm). Figures in parenthesis = millimeters

1: PUMP SPECS

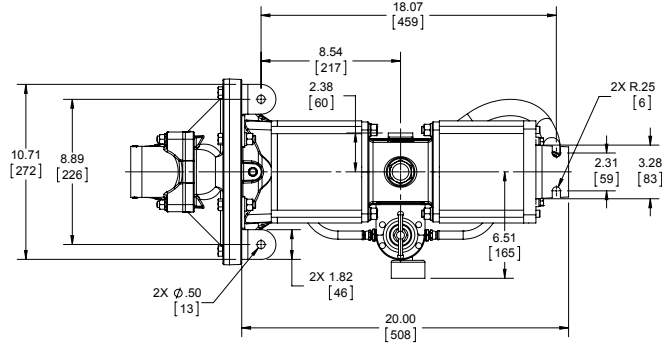
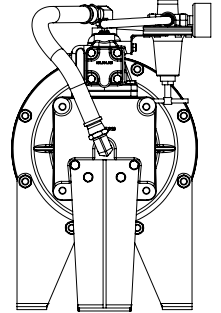
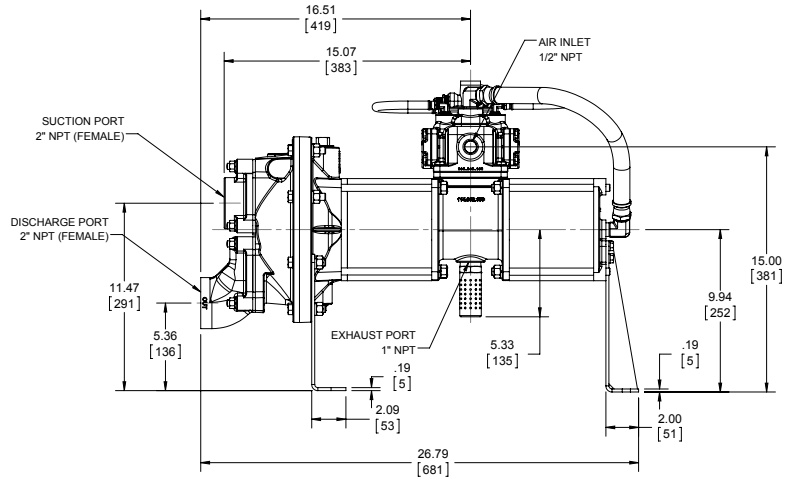
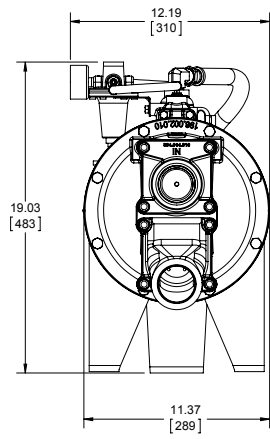

Principle of Pump Operation

PRINCIPLE OF OPERATION

This pump is a 2:1 pressure ratio single acting pump powered by compressed air. The 2:1 ratio is achieved by simultaneously applying air pressure over a single end of each of two pistons connected in series by a shaft. The two pressurized ends are those most distant from the pumped fluid, with the force from the air pressure exerted in the direction of the pumped fluid. The combined force is transferred through to the single end of the piston nearer to the pumped fluid—the single piston end having an area equal to one-half that of the two “air” ends—and then through a fluid cell to a single pumping diaphragm.

On this single acting pump the suction stroke is independent of all discharge conditions and requires less air pressure than the discharge stroke. The suction stroke is accomplished through an air regulator which pressurizes the piston area in the rear cylinder adjacent to the intermediate bracket, while simultaneously exhausting the other two piston areas: one in the front cylinder, adjacent to the intermediate bracket, and the other behind the rear cylinder piston, adjacent to the cap end.

OPERATION

The regulator is factory preset to 30 psi. After the pump is installed and in operation, the operator should raise or lower the setting until maximum performance is determined by trial and error. A setting which is too high will result in excessively rapid and noisy operation, with a loss in performance and eventually shortened pump life. The hose assemblies deliver air to the non-wetted portions of the pump, and care should be taken that they are neither crimped nor cut.

INSTALLATION PROCEDURES

Position the pump as close as possible to the source of the liquid to be pumped. Avoid long or undersize suction lines and use the minimum number of fittings. For permanent installation involving rigid piping, install short flexible sections of hose between the pump and piping. This reduces strains and permits easier removal of the pump for service when required.

AIR SUPPLY

Do not connect the unit to an air supply in excess of 125 PSI (8.61 bars). Install a shutoff valve in the air supply line to permit removal of the unit for servicing. When connecting an air supply of rigid piping, mount a section of flexible line to the pump to eliminate piping strain. In permanent installations, an air-line filter is recommended.

FREEZING OR ICING OF EXHAUST

Icing of the air exhaust can occur under certain conditions of temperature and humidity on compressed air power equipment. Icing is more likely to occur at high discharge pressures. Use of the Warren Rupp Air Dryer should eliminate the problem.

MAINTENANCE AFTER USE

When the pump is used for materials that tend to settle out or transform from liquid to solid form, care must be taken after each use or during idle time to remove them and flush the pump as required to prevent damage. In freezing temperatures the pump must be completely drained when idle. This model must be tilted to allow the liquid from the chambers to run out of the discharge port.

CAUTION



The air exhaust should be piped to an area for safe disposition of the product being pumped, in the event of a diaphragm failure.

Troubleshooting Guide

TROUBLE SHOOTING

1. Pump will not cycle

- A. Check to make sure the unit has enough pressure to operate and that the air inlet valve is open.
- B. Check the discharge line to insure that the discharge line is neither closed nor blocked.
- C. If the spool in the air distribution valve is not shifting check the main spool. It must slide freely.
- D. Excessive air leakage in the pump can prevent cycling. Air leakage from the exhaust port indicates leakage in the air distribution valve. See further service instructions.
- E. Blockage in the liquid chamber can impede movement of diaphragm.

2. Pump cycles but will not pump

- A. Suction side of pump pulling in air. Check the suction line for air leaks and be sure that the end of the suction line is submerged. Check flange bolting. Check valve flanges and manifolds to chamber flange joints.
- B. Make certain the suction line or strainer is not plugged. Restriction at the suction is indicated by a high vacuum reading when a vacuum gauge is installed in the suction line.
- C. Check valves may not be seating properly. To check, remove the suction line and cover the suction port with your hand. If the unit does not pull a good suction (vacuum), the check valves should be inspected for proper seating.
- D. Static suction lift may be too high. Priming can be improved by elevating the suction and discharge lines higher than the check valves and pouring liquid into the unit through the suction inlet. When priming at high suction lifts or with long suction lines operate the pump at maximum cycle rate.

3. Low performance

- A. Capacity is reduced as the discharge pressure increases. Performance capability varies with available inlet supply. Check air pressure at the pump inlet when the pump is operating to make certain that adequate air supply is maintained.
- B. Check vacuum at the pump suction. Capacity is reduced as vacuum increases. Reduced flow rate due to starved suction will be evident when cycle rate can be varied without change in capacity. This condition will be more prevalent when pumping viscous liquids. When pumping thick, heavy material the suction line must be kept as large in diameter and as short as possible, to keep suction loss minimal.
- C. Low flow rate and slow cycling rate indicate restricted flow through the discharge line. Low flow rate and fast cycling rate indicate restriction in the suction line or air leakage into suction. For more information, refer to the Warren Rupp Troubleshooting Guide.

WARRANTY: This unit is guaranteed for a period of five years against defective material and workmanship.

For high pressure pumps used in conjunction with another diaphragm pump in "skid mount" system: The EH2-M will not prime against the head created by the fill pump. Run both simultaneously at start-up.

RECOMMENDED WARREN RUPP® ACCESSORIES TO MAXIMIZE PUMP PERFORMANCE:

- **Tranquilizer® Surge Suppressor.** For nearly pulse-free flow.
- **Warren Rupp Air Dryer.** For clean, dry compressed air.
- **Warren Rupp Filter/Regulator.** For modular installation and service convenience.
- **Warren Rupp Speed Control.** For manual or programmable process control. Manual adjustment or 4-20mA reception.

For more detailed information on these accessories, contact your local Warren Rupp Factory-Authorized Distributor, or Warren Rupp corporate headquarters.

Composite Repair Parts Drawing

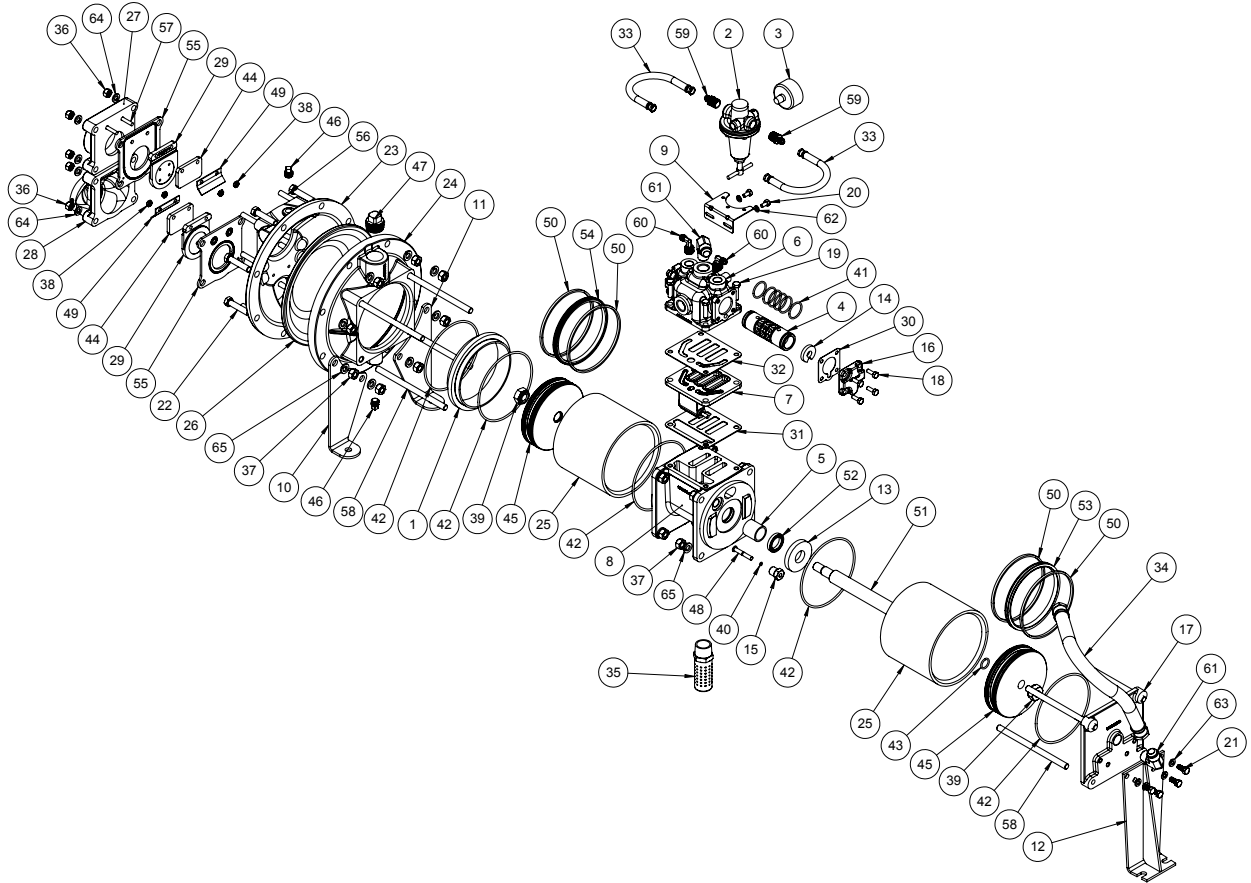

Service & Repair Kits-Cast Iron Wetted

- 476.247.000 Air End Kit**
Sleeve and Spool Set, O-rings, Bumpers, U-Cup Seals, and Gaskets, and pilot valve assembly
- 476.055.360 Wet End Kit**
Buna diaphragm, Buna flap valves, Buna hinge pads and stainless/Buna seats
- 476.055.363 Wet End Kit**
FKM diaphragm, FKM flap valves, FKM hinge pads and stainless/FKM seats
- 476.055.364 Wet End Kit**
EPDM diaphragm, EPDM flap valves, EPDM hinge pads and stainless/EPDM seats
- 476.055.365 Wet End Kit**
Neoprene diaphragm, Neoprene flap valves, Neoprene hinge pads and stainless/Neoprene seats

Composite Repair Parts List

Item	Part Number	Description	Qty.				
1	008.130.080	Adapter	1	39	547.009.080	Nut, Sealing	2
2	020.008.000	Regulator (Includes Item #3)	1	40	560.001.360	O-ring	2
3	020.054.000	Gauge, Pressure (Included with item #2)	1	41	560.020.360	O-ring	6
4	031.012.000	Sleeve and Spool Set	1	42	560.022.360	O-ring	5
5	070.006.170H	Bearing, Sleeve (Included with item #8)	2	43	560.076.360	O-ring	2
6	095.040.156	Body, Valve	1	44	570.001.360	Pad, Hinge - Buna	2
7	095.073.001	Pilot Valve Assy	1		570.001.363	Pad, Hinge - FKM	2
8	114.002.156 H	Intermediate (Includes item #5)	1		570.001.364	Pad, Hinge - EPDM	2
9	115.045.000	Bracket, Regulator (Included with item #2)	1		570.001.365	Pad, Hinge - Neoprene	2
10	115.062.080	Bracket, Mounting, Left-Hand	1	45	605.012.151	Piston	2
11	115.063.080	Bracket, Mounting, Right-Hand	1	46	618.003.330	Plug, NPT 1/4" (Included with item #23, 24)	2
12	115.075.080	Bracket, Mounting	1	47	618.007.330	Plug, NPT 1"	1
13	132.002.360	Bumper, Diaphragm	2	48	620.011.114	Plunger, Actuator	2
14	132.014.358	Bumper, Air Valve	2	49	670.005.110	Retainer, Flap Valve	2
15	135.016.162	Bushing, Threaded	2	50	677.001.542	Ring, Wear	4
16	165.011.157	Cap, End	2	51	685.043.120	Rod, Connecting	1
17	165.047.010	Cap, Cylinder	1	52	720.004.360	Seal, U-Cup	2
18	170.032.330	Capscrew, Hx-Hd 1/4-20 x 3/4	8	53	720.022.360	Seal, T Assembly with Backup Rings	1
19	170.045.330	Capscrew, Hx-Hd 5/16-18 x 1.25	4	54	720.034.000	Seal, PSP Assembly with Energizer Ring	1
20	170.050.330	Capscrew, Hx-Hd 1/4-20 x 1/2	2	55	722.070.360	Seat, Flap Valve - Buna	2
21	170.057.330	Capscrew, Hx-Hd 5/16-18 x .75	4		722.070.363	Seat, Flap Valve - FKM	2
22	170.060.330	Capscrew, Hx-Hd 7/16-14 x 2.00	8		722.070.364	Seat, Flap Valve - EPDM	2
23	196.002.010	Chamber, Outer - Cast Iron Wetted (Includes item #46, 56, 57)	1		722.070.365	Seat, Flap Valve - Neoprene	2
	196.002.155	Chamber, Outer - Aluminum Wetted (Includes item #46, 56, 57)		56	807.008.330	Stud - 3/8 (Included with item #23)	8
				57	807.018.110	Stud - 1/4 (Included with item #23, 27)	4
				58	807.047.080	Stud - 7/16	8
24	196.029.015	Chamber, Inner (Includes item #46)	1	59	866.025.162	Connector, Male	2
25	275.009.331	Cylinder	2	60	866.040.162	Fitting, Male 90° Elbow	2
26	286.036.354	Diaphragm - Santoprene	1	61	866.041.162	Fitting, Male 90° Elbow	2
	286.036.360	Diaphragm - Buna	1	62	900.001.330	Washer, Lock 1/4"	2
	286.036.363	Diaphragm - FKM	1	63	900.004.330	Washer, Lock 5/16"	4
	286.036.364	Diaphragm - EPDM	1	64	900.005.330	Washer, Lock 3/8"	4
	286.036.365	Diaphragm - Neoprene	1	65	900.006.330	Washer, Lock 7/16"	16
27	334.014.010	Flange, Suction - Cast Iron Wetted (Includes item # 57)	1				
	334.014.156	Flange, Suction - Aluminum Wetted (Includes item # 57)	1				
28	334.015.010	Flange, Discharge - Cast Iron Wetted	1				
	334.015.156	Flange, Discharge - Aluminum Wetted	1				
29	338.005.360	Valve, Flap - Buna	2				
	338.005.363	Valve, Flap - FKM	2				
	338.005.364	Valve, Flap - EPDM	2				
	338.005.365	Valve, Flap - Neoprene	2				
	338.010.354	Valve, Flap - Santoprene	2				
30	360.010.425	Gasket, End Cap	2				
31	360.041.379	Gasket, Air Valve	1				
32	360.048.425	Gasket, Air Valve	1				
33	426.009.000	Hose, Assembly	2				
34	426.015.000	Hose, Assembly	1				
35	530.033.000	Muffler	1				
36	545.005.330	Nut, Hex 3/8-16	8				
37	545.007.330	Nut, Hex 7/16-14	16				
38	547.002.110	Nut, Nylon Stop 1/4-20	4				

LEGEND:

○ = Items contained within Air End Kits

□ = Items contained within Wet End Kits

* Air End Kit only includes sleeve and spool set, not entire air valve assembly

Note: Kits contain components specific to the material codes.

3: EXP VIEW

Material Codes - The Last 3 Digits of Part Number

000.....Assembly, sub-assembly; and some purchased items	364.....EPDM Rubber Color coded: BLUE
010.....Cast Iron	365.....Neoprene Rubber Color coded: GREEN
015.....Ductile Iron	366.....Food Grade Nitrile
020.....Ferritic Malleable Iron	368.....Food Grade EPDM
080.....Carbon Steel, AISI B-1112	371.....Philthane (Tuftane)
110.....Alloy Type 316 Stainless Steel	374.....Carboxylated Nitrile
111.....Alloy Type 316 Stainless Steel (Electro Polished)	375.....Fluorinated Nitrile
112.....Alloy C	378.....High Density Polypropylene
113.....Alloy Type 316 Stainless Steel (Hand Polished)	379.....Conductive Nitrile
114.....303 Stainless Steel	408.....Cork and Neoprene
115.....302/304 Stainless Steel	425.....Compressed Fibre
117.....440-C Stainless Steel (Martensitic)	426.....Blue Gard
120.....416 Stainless Steel (Wrought Martensitic)	440.....Vegetable Fibre
148.....Hardcoat Anodized Aluminum	500.....Delrin® 500
150.....6061-T6 Aluminum	502.....Conductive Acetal, ESD-800
152.....2024-T4 Aluminum (2023-T351)	503.....Conductive Acetal, Glass-Filled
155.....356-T6 Aluminum	506.....Delrin® 150
156.....356-T6 Aluminum	520.....Injection Molded PVDF Natural color
157.....Die Cast Aluminum Alloy #380	540.....Nylon
158.....Aluminum Alloy SR-319	542.....Nylon
162.....Brass, Yellow, Screw Machine Stock	544.....Nylon Injection Molded
165.....Cast Bronze, 85-5-5-5	550.....Polyethylene
166.....Bronze, SAE 660	551.....Glass Filled Polypropylene
170.....Bronze, Bearing Type, Oil Impregnated	552.....Unfilled Polypropylene
180.....Copper Alloy	555.....Polyvinyl Chloride
305.....Carbon Steel, Black Epoxy Coated	556.....Black Vinyl
306.....Carbon Steel, Black PTFE Coated	558.....Conductive HDPE
307.....Aluminum, Black Epoxy Coated	570.....Rulon II®
308.....Stainless Steel, Black PTFE Coated	580.....Ryton®
309.....Aluminum, Black PTFE Coated	600.....PTFE (virgin material) Tetrafluorocarbon (TFE)
313.....Aluminum, White Epoxy Coated	603.....Blue Gylon®
330.....Zinc Plated Steel	604.....PTFE
332.....Aluminum, Electroless Nickel Plated	606.....PTFE
333.....Carbon Steel, Electroless Nickel Plated	607.....Envelon
335.....Galvanized Steel	608.....Conductive PTFE
337.....Silver Plated Steel	610.....PTFE Encapsulated Silicon
351.....Food Grade Santoprene®	611.....PTFE Encapsulated FKM
353.....Geolast; Color: Black	632.....Neoprene/Hytrel®
354.....Injection Molded #203-40 Santoprene® Duro 40D +/-5; Color: RED	633.....FKM/PTFE
356.....Hytrel®	634.....EPDM/PTFE
357.....Injection Molded Polyurethane	635.....Neoprene/PTFE
358.....Urethane Rubber (Some Applications) (Compression Mold)	637.....PTFE, FKM/PTFE
359.....Urethane Rubber	638.....PTFE, Hytrel®/PTFE
360.....Nitrile Rubber Color coded: RED	639.....Nitrile/TFE
363.....FKM (Fluorocarbon) Color coded: YELLOW	643.....Santoprene®/EPDM
	644.....Santoprene®/PTFE
	656.....Santoprene® Diaphragm and Check Balls/EPDM Seats
	661.....EPDM/Santoprene®
	666.....FDA Nitrile Diaphragm, PTFE Overlay, Balls, and Seals
	668.....PTFE, FDA Santoprene®/PTFE

- Delrin and Hytrel are registered tradenames of E.I. DuPont.
- Nylatron is a registered tradename of Polymer Corp.
- Gylon is a registered tradename of Garlock, Inc.
- Santoprene is a registered tradename of Exxon Mobil Corp.
- Rulon II is a registered tradename of Dixon Industries Corp.
- Ryton is a registered tradename of Phillips Chemical Co.
- Valox is a registered tradename of General Electric Co.

Pilot Valve Assembly

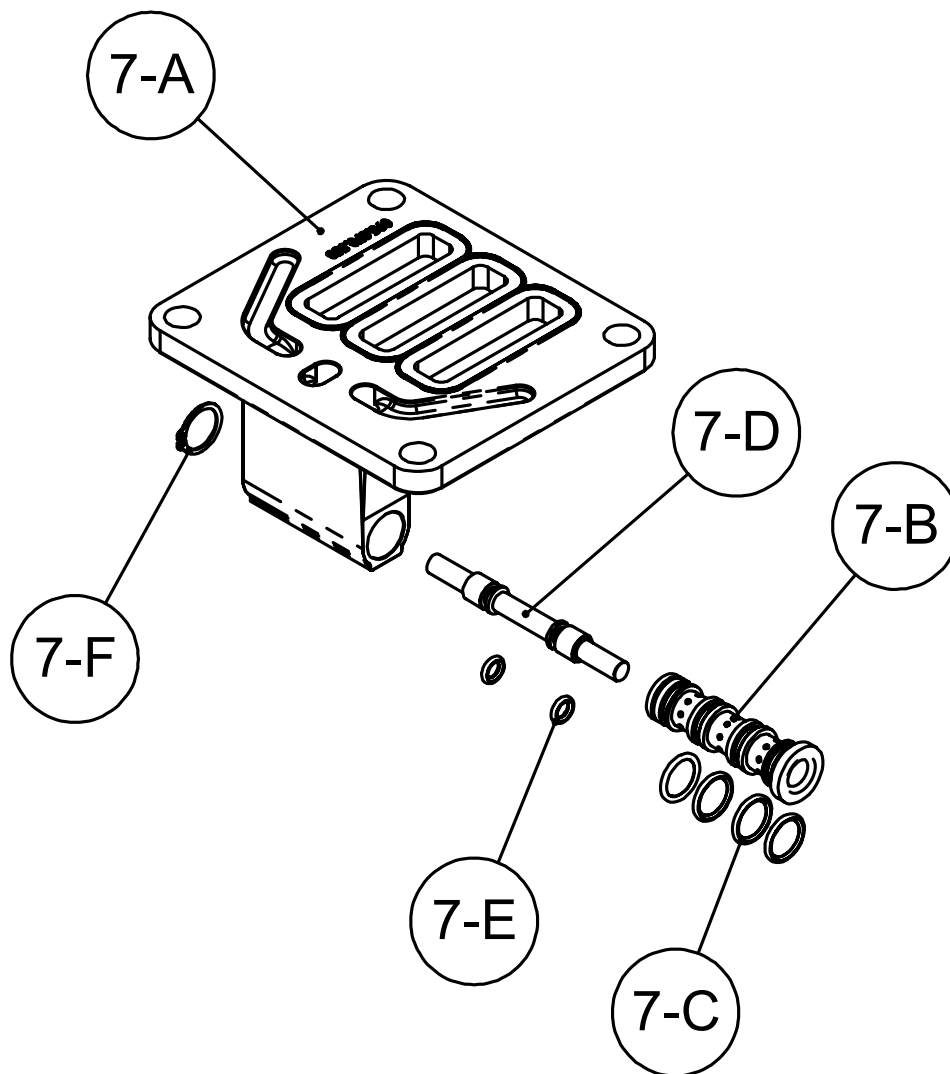

4: AIR END

Pilot Valve Servicing

With Pilot Valve removed from pump.

Step 1: Remove snap ring (7-F).

Step 2: Remove sleeve (7-B), inspect O-Rings (7-C), replace if required.

Step 3: Remove spool (7-D) from sleeve (7-B), inspect O-Rings (7-E), replace if required.

Step 4: Lightly lubricate O-Rings (7-C) and (7-E).

Reassemble in reverse order.

PILOT VALVE ASSEMBLY PARTS LIST

Item	Part Number	Description	Qty
7	095.073.001	Pilot Valve Assembly	1
7-A	095.070.558	Valve Body	1
7-B	755.025.000	Sleeve (With O-Rings)	1
7-C	560.033.360	O-Ring (Sleeve)	4
7-D	775.026.000	Spool (With O-Rings)	1
7-E	560.023.360	O-Ring (Spool)	2
7-F	675.037.080	Retaining Ring	1

IMPORTANT



Read these instructions completely, before installation and start-up. It is the responsibility of the purchaser to retain this manual for reference. Failure to comply with the recommendations stated in this manual will damage the pump, and void factory warranty.

CHECK VALVE SERVICING

Need for inspection or service is usually indicated by poor priming, unstable cycling, reduced performance or the pump's cycling but not pumping. Inspect the surface of the check valve for surface imperfections. Replace as necessary.

DIAPHRAGM SERVICING/FILLING DRIVER FLUID

Motive power is delivered to the single diaphragm of the pump through a fluid cell located between the diaphragm and the drive piston. During preventative maintenance servicing (where the diaphragm has not ruptured, and the fluid cell is still filled), the fluid should be drained from the chamber by removing the pipe plug, in the lower most portion of inner chamber. To fill the fluid cell, the piston(s) must be on full discharge stroke. To do this and hold during fill procedure, remove the fitting from the cylinder cap and insert air pressure. This need not be more than 10 PSI. The pressure will move the piston(s) and hold them in the discharge position. Remove the pipe plug at the top of the fluid chamber, and fill the chamber with ethylene glycol (anti-freeze). The chamber will take 3000 ml (101.5 fluid ounces) of fluid. If the diaphragm is Teflon, use 2800 ml (95 fluid ounces). Tilt the pump to evacuate air pockets from the fluid chamber. A box wrench can be used to flex the diaphragm and purge air from the fluid chamber. Fill the chamber to the top of the fill hole, and re-insert the pipe plug, using thread compound. If the glycol cell fluid is not compatible with the pumped product or would form a potentially dangerous mixture if the diaphragm ruptured, consult the factory before choosing an alternative fluid.

CYLINDER PISTON SERVICING

The driver fluid must be drained (see above) to service the cylinder piston. The piston seals are different on the air side versus the driver fluid side. Typically, the fluid side will require replacement before the air side. Remove the nuts and washers that secure the air side piston cap and inner fluid chamber to the intermediate bracket. The cylinders may now be removed. Inspect the cylinder wall carefully. Scratches can cause driver fluid to leak to the air side of the pump, which can find its way to the exhaust muffler. Scratches on the air cylinder will cause too much air to leak when on pressure stroke. The locknuts holding the cylinder to the rod can now be removed. Carefully inspect the piston for scratches, burrs and wear, especially if the piston seals are worn. The piston seals can now be inspected or replaced. **AIR SIDE**—The air side piston has a T-Seal. If the seal is worn showing flat areas or gouges, it will require replacement. Remove seal and back-up (spacer). Remove wear rings and carefully inspect for wear. During reassembly make sure the ends of the backup spacer and wear ring end are not across from each other. **WET SIDE**—The wet side piston has a yellow PSP seal. Inspect for flat spots and gouges. Behind the seal is an energizer ring that helps to load the seal against the cylinder wall. (The energizer ring is included with the new seal.) The wear rings are the same as on the air side. Again, make sure the ends are not across from each other. Reassembly of both pistons is the opposite of removal. Make sure the side of the **locknut with the seal is next to the piston**. The groove in the piston o-ring must be toward the pump center (o-ring seals next to the rod). Apply a heavy oil, such as STP or 50W gear oil, to the piston seals when sliding on the cylinder. The piston/nut should be torqued at 500 in-lbs. (56.49 Newton meters). The studs that secure the cylinders to the intermediate should be torqued at 250 in-lbs. (28.24 Newton meters).

IMPORTANT NOTE: Reassembly of the wet side piston/seal assembly differs from the air side in that it must be carefully pressed into the cylinder. An arbor press is commonly used for this task.

AIR VALVE LUBRICATION

The SANDPIPER pump's pilot valve and main air valve assemblies are designed to operate WITHOUT lubrication. This is the preferred mode of operation. There may be instances of personal preference or poor quality air supplies when lubrication of the compressed air supply is required. The pump air distribution system will operate with a properly lubricated compressed air supply. Proper lubrication of the compressed air supply would entail the use of an air-line lubricator available from Warren Rupp, set to deliver one drop of 10 wt., non-detergent oil for every 20 SCFM of air the pump consumed at its point of operation. Consult the pump's published performance curve to determine this. It is important to remember to inspect the sleeve and spool set routinely. It should move back and forth freely. This is most important when the air supply is lubricated. If a lubricator is used, oil accumulation will, over time, collect any debris from the compressed air. This can prevent the pump from operating properly. Water in the compressed air supply can create problems such as icing or freezing of the exhaust air causing the pump to cycle erratically, or stop operating. This can be addressed by using a point of use air dryer (available from Warren Rupp) to supplement a plant's air drying equipment. This device will remove excess water from the compressed air supply and reduce the frequency of icing or freezing.

ESADS: Externally Serviceable Air Distribution System

Please refer to the exploded view drawing and parts list in the Service Manual supplied with your pump. If you need replacement or additional copies, contact your local Warren Rupp Distributor, or visit the Warren Rupp website. To receive the correct manual, you must specify the MODEL and TYPE information found on the name plate of the pump.

Main Air Valve

The main air valve sleeve and spool set is located in the valve body mounted on the pump with four hex head capscrews. The valve body assembly is removed from the pump by removing these four hex head capscrews.

With the valve body assembly off the pump, access to the sleeve and spool set is made by removing four hex head capscrews (each end) on the end caps of the valve body assembly. With the end caps removed, slide the spool back and forth in the sleeve. The spool is closely sized to the sleeve and must move freely to allow for proper pump operation. An accumulation of oil, dirt or other contaminants from the pump's air supply, or from a failed diaphragm, may prevent the spool from moving freely. This can cause the spool to stick in a position that prevents the pump from operating. If this is the case, the sleeve and spool set should be removed from the valve body for cleaning and further inspection. Remove the spool from the sleeve. Using an arbor press or bench vise (with an improvised mandrel), press the sleeve from the valve body. Take care not to damage the sleeve. At this point, inspect the o-rings on the sleeve for nicks, tears or abrasions. Damage of this sort could happen during assembly or servicing. A sheared or cut o-ring can allow the pump's compressed air supply to leak or bypass within the air valve assembly, causing the pump to leak compressed air from the pump air exhaust or not cycle properly. This is most noticeable at pump dead head or high discharge pressure conditions. Replace any of these o-rings as required or set up a routine, preventive maintenance schedule to do so on a regular basis. This practice should include cleaning the spool and sleeve components with a safety solvent or equivalent, inspecting for signs of wear or damage, and replacing worn components. To re-install the sleeve and spool set, lightly lubricate the o-rings on the sleeve with an o-ring assembly lubricant or lightweight oil (such as 10 wt. air-line lubricant). Press the set into the valve body easily, without shearing the o-rings. Re-install one end cap, gasket and bumper on the valve body. Using the arbor press or bench vise that was used in disassembly, press the sleeve back into the valve body. You may have to clean the surfaces of the valve body where the end caps mount. Material may remain from the old gasket. Old material not cleaned from this area may cause air leakage after reassembly. Take care that the bumper stays in place allowing the sleeve to press in all the way. Reinstall the spool, the opposite end cap, gasket and bumper on the valve body. After inspecting and cleaning the gasket surfaces on the valve body and intermediate, reinstall the valve body on the pump using new gaskets. Tighten the four hex head capscrews evenly and in an alternating cross pattern.

PILOT VALVE ACTUATOR SERVICING

The bushings for the pilot valve actuators are threaded into the intermediate bracket from the outside. The plunger may be removed for inspection or replacement from the inside by removing the air distribution valve body and the pilot valve body from the pump. The plungers should be visible as you look into the intermediate from the top. Depending on their position, you may find it necessary to use a fine piece of wire to pull them out. Under rare circumstances, it may become necessary to replace the o-ring seal. The bushing can be pushed through the inner chamber by removing the outer chamber the assembly to reach the bushing.

5 - YEAR Limited Product Warranty

Warren Rupp, Inc. ("Warren Rupp") warrants to the original end-use purchaser that no product sold by Warren Rupp that bears a Warren Rupp brand shall fail under normal use and service due to a defect in material or workmanship within five years from the date of shipment from Warren Rupp's factory. Warren Rupp brands include Warren Rupp®, SANDPIPER®, SANDPIPER Signature Series™, MARATHON®, Porta-Pump®, SludgeMaster™ and Tranquilizer®.

The use of non-OEM replacement parts will void (or negate) agency certifications, including CE, ATEX, CSA, 3A and EC1935 compliance (Food Contact Materials). Warren Rupp, Inc. cannot ensure nor warrant non-OEM parts to meet the stringent requirements of the certifying agencies.

~ See sandpiperpump.com/content/warranty-certifications for complete warranty, including terms and conditions, limitations and exclusions. ~

**WARREN
RUPP, INC.**

Declaration of Conformity

Manufacturer: Warren Rupp, Inc., 800 N. Main Street
Mansfield, Ohio, 44902 USA

Certifies that Air-Operated Double Diaphragm Pump Series: HDB, HDF, M Non-Metallic, S Non-Metallic, M Metallic, S Metallic, T Series, G Series, U Series, EH and SH High Pressure, RS Series, W Series, SMA and SPA Submersibles, and Tranquilizer® Surge Suppressors comply with the European Community Directive 2006/42/EC on Machinery, according to Annex VIII. This product has used Harmonized Standard EN809:1998+A1:2009, Pumps and Pump Units for Liquids - Common Safety Requirements, to verify conformance.

Signature of authorized person

October 20, 2005
Date of issue

Authorised Representative:
IDEX Pump Technologies
R79 Shannon Industrial Estate
Shannon, Co. Clare, Ireland

Director of Engineering
Title

February 27, 2017
Date of revision

Attn: Barry McMahon



Revision Level: F



WARREN RUPP, INC.

EC / EU Declaration of Conformity

The objective of the declaration described is in conformity with the relevant Union harmonisation legislation: Directive 94/9/EC (until April 19, 2016) and Directive 2014/34/EU (from April 20, 2016).

Manufacturer:

Warren Rupp, Inc.
A Unit of IDEX Corporation
800 North Main Street
P.O. Box 1568
Mansfield, OH 44902 USA

Applicable Standard:

EN13463-1: 2001
EN13463-5: 2003
EN60079-25: 2004

Harmonised Standard:

EN13463-1: 2009
EN13463-5: 2011
EN60079-25:2010

The harmonised standards have been compared to the applicable standards used for certification purposes and no changes in the state of the art technical knowledge apply to the listed equipment.

AODD Pumps and Surge Suppressors

Technical File No.: 203104000-1410/MER

AODD (Air-Operated Double Diaphragm) Pumps

EC Type Examination Certificate No. Pumps: KEMA 09ATEX0071 X

DEKRA Certification B.V. (0344)
Meander 1051
6825 MJ Arnhem
The Netherlands

Hazardous Locations Applied:

I M1 c	II 1 G c T5
II 2 G Ex ia c IIC T5	II 1 D c T100°C
II 2 D Ex c iaD 20 IP67 T100°C	II 2 G c T5
II 2 G Eex m c II T5	II 2 D c T100°C
II 2 D c IP65 T100°C	II 2 G c IIB T5

SANDPIPER®
A WARREN RUPP, INC. BRAND

Tranquilizer®

DATE/APPROVAL/TITLE:
18 March 2016

David Roseberry
David Roseberry, Director of Engineering

IDEX