

SERVICE & OPERATING MANUAL

Original Instructions

G SERIES

Certified Quality



ISO 9001 Certified
ISO 14001 Certified



Certified to CSA Technical Letter No, R-14



Certified to ANSI LC6-2008



Warren Rupp, Inc.
A Unit of IDEX Corporation
800 N. Main St.,
Mansfield, Ohio 44902 USA
Telephone 419.524.8388
Fax 419.522.7867
SANDPIPERPUMP.COM



© Copyright 2017 Warren Rupp, Inc.
All rights reserved

Model G20F

Metallic Flap Valve Design Level 1

Natural Gas-Operated Diaphragm Pumps

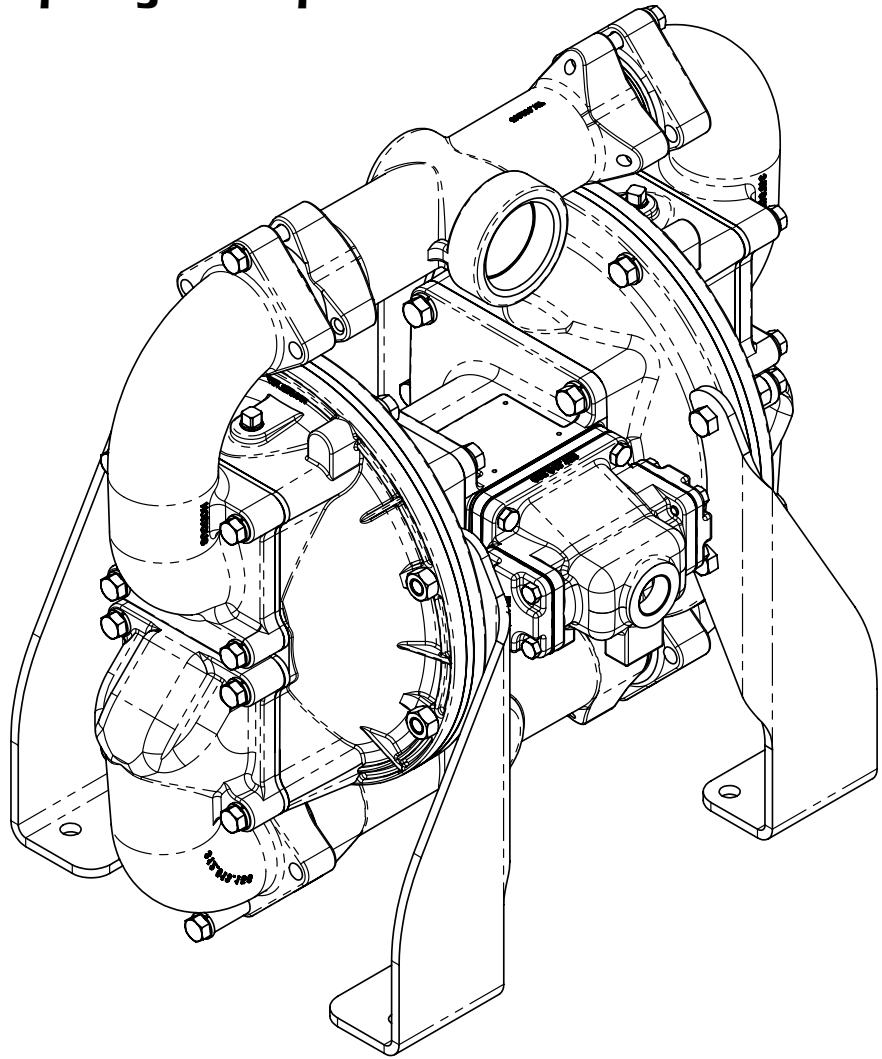

1: PUMP SPECS

2: INSTAL & OP

3: EXP VIEW

4: Gas END

5: WET END

6: OPTIONAL

7: WARRANTY

SANDPIPER®

A WARREN RUPP, INC. BRAND

SANDPIPERPUMP.COM

Safety Information

IMPORTANT



Read the safety warnings and instructions in this manual before pump installation and start-up. Failure to comply with the recommendations stated in this manual could damage the pump and void factory warranty.



When the pump is used for materials that tend to settle out or solidify, the pump should be flushed after each use to prevent damage. In freezing temperatures the pump should be completely drained between uses.

CAUTION



Before pump operation, inspect all fasteners for loosening caused by gasket creep. Retighten loose fasteners to prevent leakage. Follow recommended torques stated in this manual.



Nonmetallic pumps and plastic components are not UV stabilized. Ultraviolet radiation can damage these parts and negatively affect material properties. Do not expose to UV light for extended periods of time.



WARNING
The use of non-OEM replacement parts will void (or negate) agency certifications, including CE, ATEX, CSA, 3A and EC1935 compliance (Food Contact Materials). Warren Rupp, Inc. cannot ensure nor warrant non-OEM parts to meet the stringent requirements of the certifying agencies.

WARNING



When used for toxic or aggressive fluids, the pump should always be flushed clean prior to disassembly.



Before maintenance or repair, shut off the compressed gas line, bleed the pressure, and disconnect the gas line from the pump. Be certain that approved eye protection and protective clothing are worn at all times. Failure to follow these recommendations may result in serious injury or death.



Airborne particles and loud noise hazards. Wear eye and ear protection.



In the event of diaphragm rupture, pumped material may enter the air end of the pump, and be discharged into the atmosphere. If pumping a product that is hazardous or toxic, the air exhaust must be piped to an appropriate area for safe containment.



Take action to prevent static sparking. Fire or explosion can result, especially when handling flammable liquids. The pump, piping, valves, containers and other miscellaneous equipment must be properly grounded.



This pump is pressurized internally with gas pressure during operation. Make certain that all fasteners are in good condition and are reinstalled properly during reassembly.



Use safe practices when lifting

Grounding ATEX Pumps

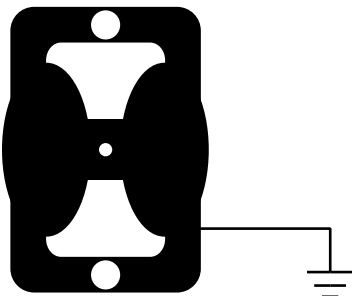

ATEX compliant pumps are suitable for use in explosive atmospheres when the equipment is properly grounded in accordance with local electrical codes. Pumps equipped with electrically conductive diaphragms are suitable for the transfer of conductive or non-conductive fluids of any explosion group. When operating pumps equipped with non-conductive diaphragms that exceed the maximum permissible projected area, as defined in EN 13463-1: 2009 section 6.7.5 table 9, the following protection methods must be applied:

- Equipment is always used to transfer electrically conductive fluids or
- Explosive environment is prevented from entering the internal portions of the pump, i.e. dry running

For further guidance on ATEX applications, please consult the factory.

Table of Contents

SECTION 1: PUMP SPECIFICATIONS.....1

- Explanation of Nomenclature
- Performance
- Materials
- Dimensional Drawings

SECTION 2: INSTALLATION & OPERATION.....5

- Principle of Pump Operation
- Recommended Installation Guide
- Troubleshooting Guide

SECTION 3: EXPLODED VIEW.....8

- Composite Repair Parts Drawing
- Composite Repair Parts List
- Material Codes

SECTION 4: GAS END11

- Gas Valve Assembly
- Pilot Valve Assembly

SECTION 5: WET END14

- Diaphragm Servicing
- Pumping Hazardous Liquids

SECTION 7: WARRANTY & CERTIFICATES17

- Warranty
- CE Declaration of Conformity - Machinery
- ATEX Declaration of Conformity

1: PUMP SPECS

2: INSTAL & OP

3: EXP VIEW

4: AIR END

5: WET END

6: OPTIONAL

7: WARRANTY

Explanation of Pump Nomenclature

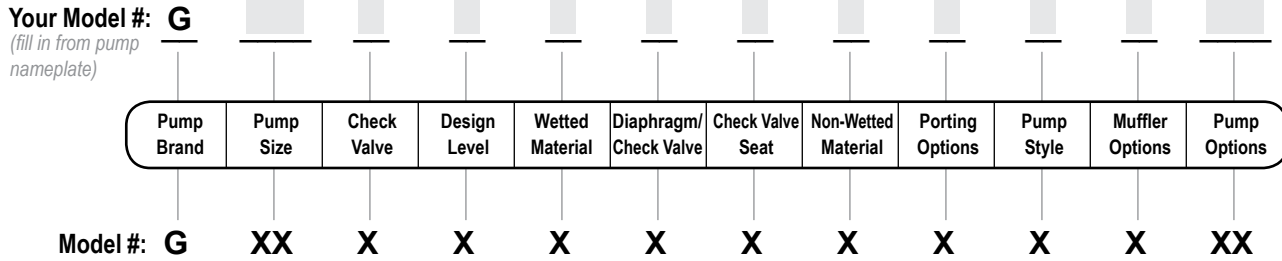

Pump Brand

G Gas Operated

Pump Size

20 2"

Check Valve Type

F Flap

Design Level

1 Design Level

Wetted Material

S Painted Stainless Steel
A Painted Aluminum

Diaphragm/Check Valve Materials

B Nitrile/Nitrile
V FKM/FKM

Check Valve Seat

S Stainless Steel

Non-Wetted Material Options

A Painted Aluminum with Nitrile Elastomer Parts
V Painted Aluminum with FKM Elastomer Parts

Porting Options

N NPT Threads

Pump Style

S Standard

Muffler Options

X No Muffler Permitted *

Your Serial #: (fill in from pump nameplate) _____

ATEX Detail



II 2G c T5
II 2D c T100°C

Performance

G20F NATURAL GAS-OPERATED

SUCTION/DISCHARGE PORT SIZE

• 2"

CAPACITY

• 0 to 140 gallons per minute
(0 to 530 liters per minute)

GAS DISTRIBUTION VALVE

• No-lube, no-stall design

SOLIDS-HANDLING

• Up to 2 in. (50mm)

HEADS UP TO

• 100 psi or 231 ft. of water
(7 bar or 70 meters)

MAXIMUM OPERATING PRESSURE

• 100 psi (7 bar)

DISPLACEMENT/STROKE

• .42 Gallon / 1.59 liter

SHIPPING WEIGHT

• Aluminum 69 lbs. (31kg)
• Stainless Steel 114 lbs. (52kg)

These pump models are designed to pump the following fluids:
Crude Oil, Salt Water, Drilling Mud, Condensate, Lubrication Oils,
Glycol, Caustic Liquids, and Acids."

MODEL G20F Performance Curve

Performance based on the following: elastomer fitted pump, flooded suction, water at ambient conditions.
The use of other materials and varying hydraulic conditions may result in deviations in excess of 5%.

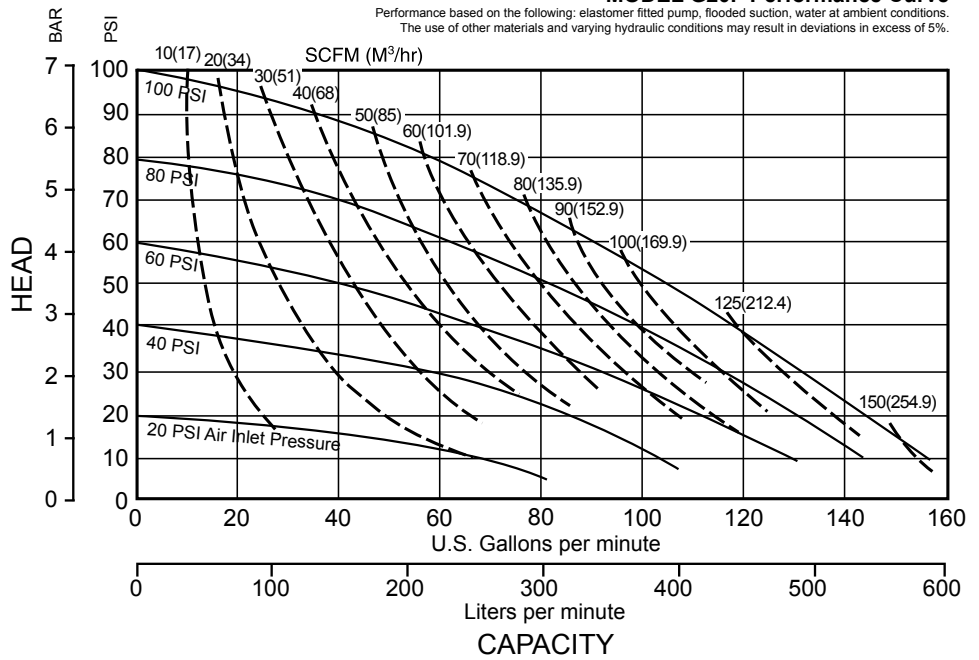

Exhaust Gas: The exhausted natural gas must be vented to a low pressure safe location in accordance with local fire safety and environmental codes, or in the absence of local codes, an industry or nationally recognized code having jurisdiction over the specific installations, and/or CAN/CGA B149, Installation Codes

Materials

Material Profile:

CAUTION! Operating temperature limitations are as follows:

FKM: (Fluorocarbon) Shows good resistance to a wide range of oils and solvents; especially all aliphatic, aromatic and halogenated hydrocarbons, acids, animal and vegetable oils. Hot water or hot aqueous solutions (over 70°F(21°C)) will attack FKM.

Nitrile: General purpose, oil-resistant. Shows good solvent, oil, water and hydraulic fluid resistance. Should not be used with highly polar solvents like acetone and MEK, ozone, chlorinated hydrocarbons and nitro hydrocarbons.

Maximum and Minimum Temperatures are the limits for which these materials can be operated. Temperatures coupled with pressure affect the longevity of diaphragm pump components. Maximum life should not be expected at the extreme limits of the temperature ranges.

Metals:

Stainless Steel: Equal to or exceeding ASTM specification A743 CF-8M for corrosion resistant iron chromium, iron chromium nickel and nickel based alloy castings for general applications. Commonly referred to as 316 Stainless Steel in the pump industry.

For specific applications, always consult the Chemical Resistance Chart.

Ambient temperature range: -20°C to +40°C

Process temperature range: -20°C to +100°C for models rated as category 2 equipment

In addition, the ambient temperature range and the process temperature range do not exceed the operating temperature range of the applied non-metallic parts as listed in the manuals of the pumps.

Dimensional Drawings

G20F Metallic

Dimensions in inches (mm dimensions in brackets). Dimensional Tolerance: $\pm 1/8"$ ($\pm 3\text{mm}$)

The dimensions on this drawing are for reference only. A certified drawing can be requested if physical dimensions are needed.

1: PUMP SPECS

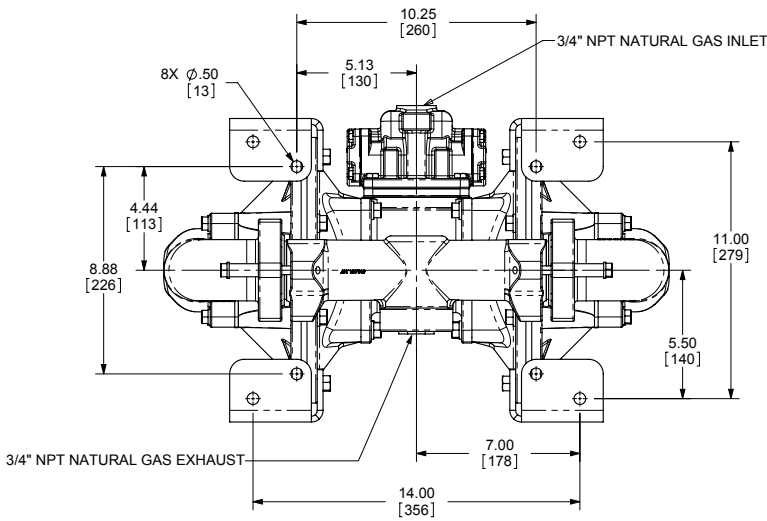
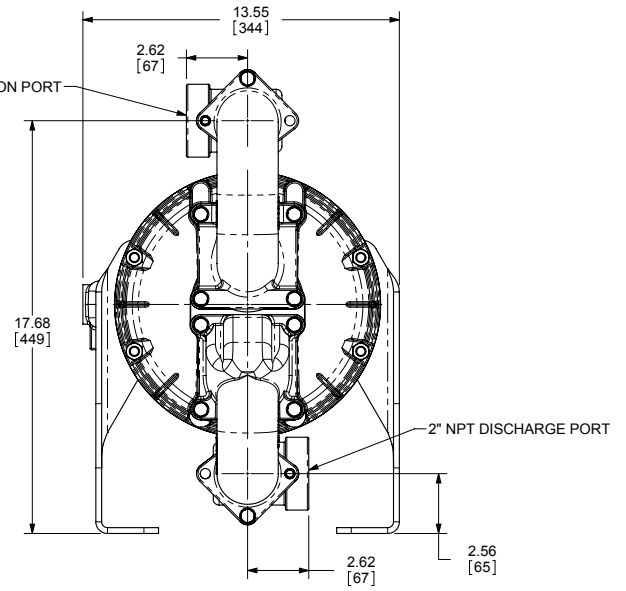
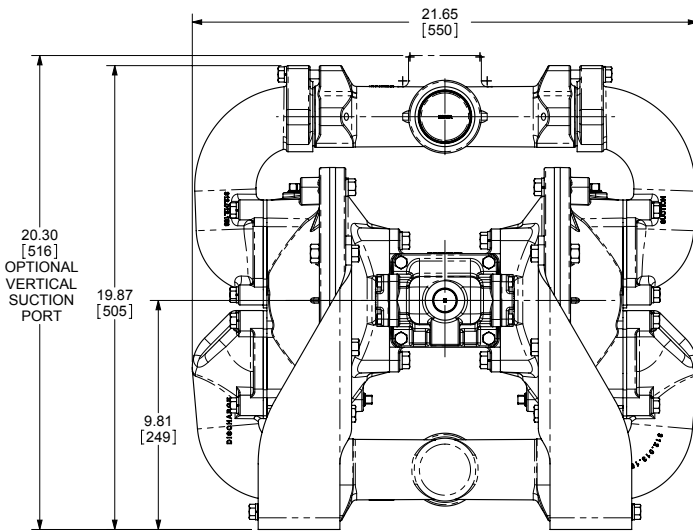

Principle of Pump Operation

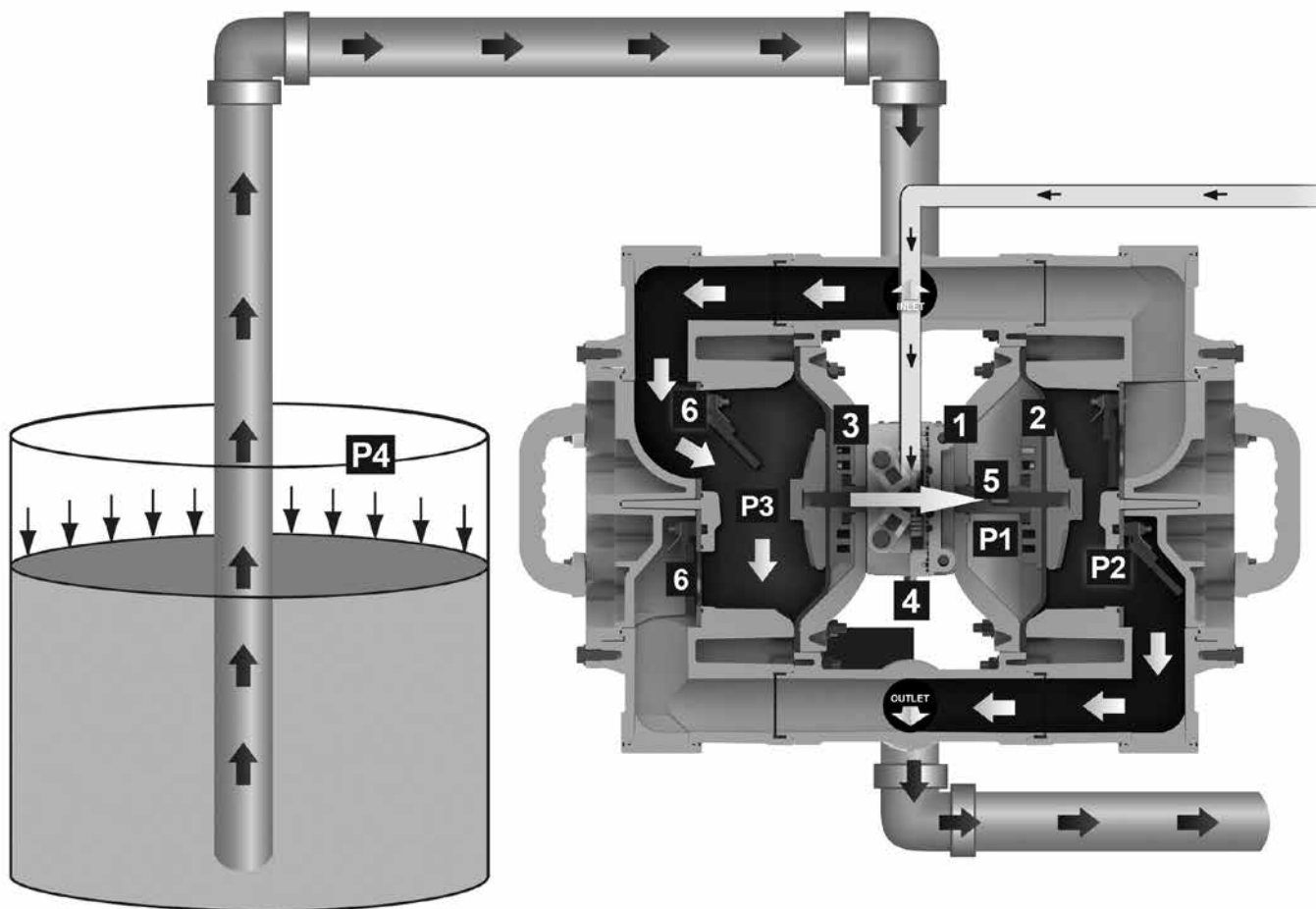

Gas-Operated Double Diaphragm (GODD) pumps are powered by compressed air or nitrogen.

The main directional (air) control valve distributes compressed air to an air chamber, exerting uniform pressure over the inner surface of the diaphragm. At the same time, the exhausting air from behind the opposite diaphragm is directed through the air valve assembly(s) to an exhaust port.

As inner chamber pressure (P1) exceeds liquid chamber pressure (P2), the rod connected diaphragms shift together creating discharge on one side and suction on the opposite side. The discharged and primed liquid's directions are controlled by the check valves (ball or flap) orientation.

The pump primes as a result of the suction stroke. The suction stroke lowers the chamber pressure (P3) increasing the chamber volume. This results in a pressure differential necessary for atmospheric pressure (P4) to push the fluid through the suction piping and across the suction side check valve and into the outer fluid chamber.

Suction (side) stroking also initiates the reciprocating (shifting, stroking or cycling) action of the pump. The suction diaphragm's movement is mechanically pulled through its stroke. The diaphragm's inner plate makes contact with an actuator plunger aligned to shift the pilot signaling valve. Once actuated, the pilot valve sends a pressure signal to the opposite end of the main directional air valve, redirecting the compressed air to the opposite inner chamber.

Recommended Installation Guide

- ① 020.064.000 Filter
VENTING WARNING: This filter is equipped with a stainless steel manual drain. The port is 1/8" NPT. When draining moisture from the filter, first shut off the natural gas supply.
- ② 020.059.000 REGULATED SHUT-OFF VALVE
PRESSURE WARNING: This regulator is to be installed at point of use with the pump. The maximum gas supply is 400psi. Full line pressure needs to be regulated below 400psi prior to the regulator installation position.

වැදගත්කමක් සහතිකයක්: This regulator is equipped with a 1/4" NPT vent port. In the event of a diaphragm rupture, natural gas can be exhausted into the surrounding environment. Connect a conductive hose or pipe to the vent port to send the escaping natural gas to a safe area for gas reclamation. Make sure to ground the regulator, hose, and/or pipe.

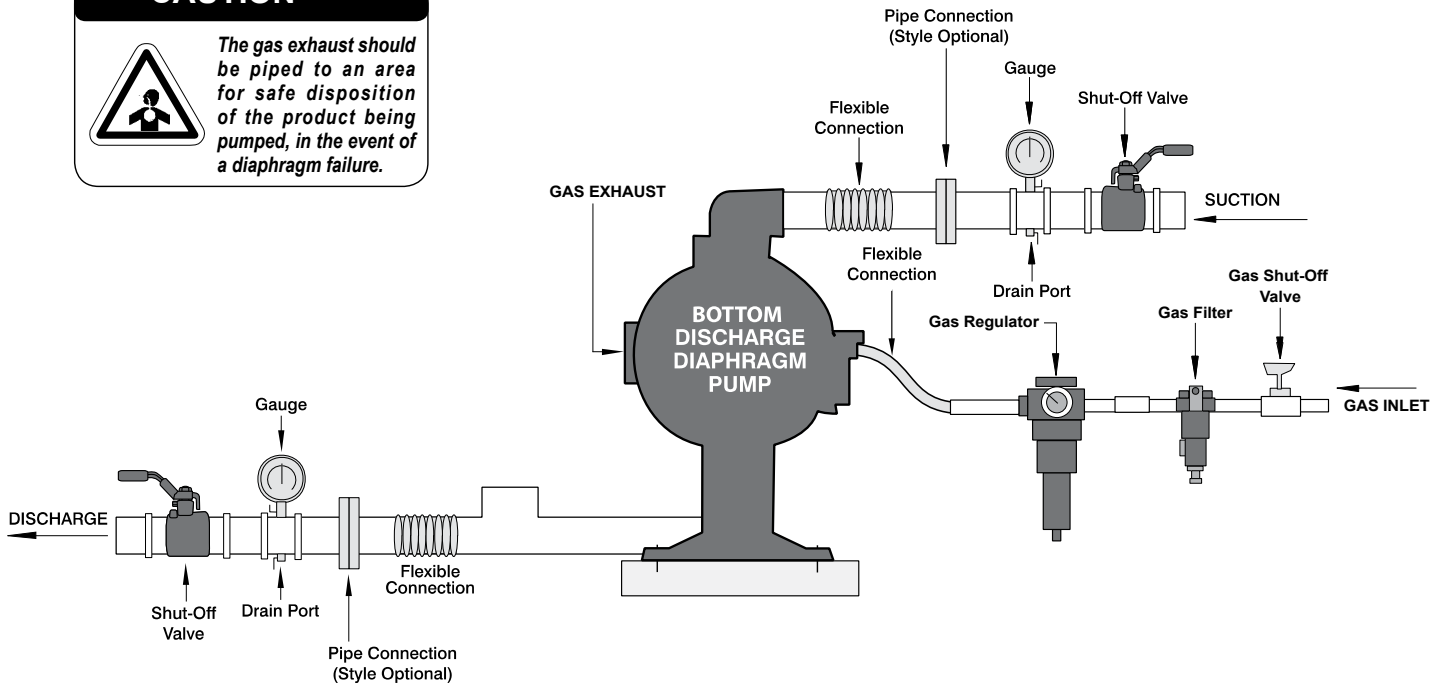
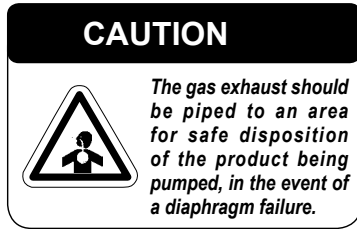

Installation And Start-Up

Locate the pump as close to the product being pumped as possible. Keep the suction line length and number of fittings to a minimum. Do not reduce the suction line diameter.

Gas Supply

Connect the pump gas inlet to a gas supply with sufficient capacity and pressure to achieve desired performance. A pressure regulating valve should be installed to insure gas supply pressure does not exceed recommended limits.

Gas Valve Lubrication

The gas distribution system is designed to operate WITHOUT lubrication. This is the standard mode of operation. If lubrication is desired, install a gas line lubricator set to deliver one drop of SAE 10 non-detergent oil for every 20 SCFM (9.4 liters/sec.) of gas the pump consumes. Consult the Performance Curve to determine gas consumption.

Gas Line Moisture

Water in the compressed gas supply may cause icing or freezing of the exhaust gas, causing the pump to cycle erratically or stop operating. Water in the gas supply can be reduced by using a point-of-use gas dryer.

Gas Inlet And Priming

To start the pump, slightly open the gas shut-off valve. After the pump primes, the gas valve can be opened to increase gas flow as desired. If opening the valve increases cycling rate, but does not increase the rate of flow, cavitation has occurred. The valve should be closed slightly to obtain the most efficient gas flow to pump flow ratio.

Troubleshooting Guide

Symptom:	Potential Cause(s):	Recommendation(s):
Pump Cycles Once	Deadhead (system pressure meets or exceeds gas supply pressure).	Increase the inlet gas pressure to the pump. Pump is designed for 1:1 pressure ratio at zero flow. (Does not apply to high pressure 2:1 units).
	Gas valve or intermediate gaskets installed incorrectly.	Install gaskets with holes properly aligned.
	Bent or missing actuator plunger.	Remove pilot valve and inspect actuator plungers.
Pump Will Not Operate / Cycle	Pump is over lubricated.	Set lubricator on lowest possible setting or remove. Units are designed for lube free operation.
	Lack of gas (line size, PSI, CFM).	Check the gas line size and length, compressor capacity (HP vs. cfm required).
	Check gas distribution system.	Disassemble and inspect main gas distribution valve, pilot valve and pilot valve actuators.
	Discharge line is blocked or clogged manifolds.	Check for inadvertently closed discharge line valves. Clean discharge manifolds/piping.
	Deadhead (system pressure meets or exceeds gas supply pressure).	Increase the inlet gas pressure to the pump. Pump is designed for 1:1 pressure ratio at zero flow. (Does not apply to high pressure 2:1 units).
	Blocked gas exhaust muffler.	Remove muffler screen, clean or de-ice, and re-install.
	Pumped fluid in gas exhaust muffler.	Disassemble pump chambers. Inspect for diaphragm rupture or loose diaphragm plate assembly.
	Pump chamber is blocked.	Disassemble and inspect wetted chambers. Remove or flush any obstructions.
Pump Cycles and Will Not Prime or No Flow	Cavitation on suction side.	Check suction condition (move pump closer to product).
	Check valve obstructed. Flap valve(s) not seating properly or sticking.	Disassemble the wet end of the pump and manually dislodge obstruction in the check valve pocket. Clean out around flap valve(s) and valve seat area. Replace flap valve(s) or valve seat if damaged.
	Flap valve(s)/seat(s) damaged or attacked by product.	Check Chemical Resistance Guide for compatibility.
	Check valve and/or seat is worn or needs adjusting.	Inspect check valves and seats for wear and proper setting. Replace if necessary.
	Suction line is blocked.	Remove or flush obstruction. Check and clear all suction screens or strainers.
	Excessive suction lift.	For lifts exceeding 20' of liquid, filling the chambers with liquid will prime the pump in most cases.
	Suction side gas leakage or gas in product.	Visually inspect all suction-side gaskets and pipe connections.
	Pumped fluid in gas exhaust.	Disassemble pump chambers. Inspect for diaphragm rupture or loose diaphragm plate assembly.
Pump Cycles Running Sluggish / Stalling, Flow Unsatisfactory	Over lubrication.	Set lubricator on lowest possible setting or remove. Units are designed for lube free operation.
	Icing.	De-ice, and re-install. Install a point of use gas drier.
	Clogged manifolds.	Clean manifolds to allow proper gas flow.
	Deadhead (system pressure meets or exceeds gas supply pressure).	Increase the inlet gas pressure to the pump. Pump is designed for 1:1 pressure ratio at zero flow. (Does not apply to high pressure 2:1 units).
	Cavitation on suction side.	Check suction (move pump closer to product).
	Lack of gas (line size, PSI, CFM).	Check the gas line size, length, compressor capacity.
	Excessive suction lift.	For lifts exceeding 20' of liquid, filling the chambers with liquid will prime the pump in most cases.
	Gas supply pressure or volume exceeds system hd.	Decrease inlet gas (press. and vol.) to the pump. Pump is cavitating the fluid by fast cycling.
	Undersized suction line.	Meet or exceed pump connections.
	Restrictive or undersized gas line.	Install a larger gas line and connection.
	Suction side gas leakage or gas in product.	Visually inspect all suction-side gaskets and pipe connections.
	Suction line is blocked.	Remove or flush obstruction. Check and clear all suction screens or strainers.
	Pumped fluid in gas exhaust muffler.	Disassemble pump chambers. Inspect for diaphragm rupture or loose diaphragm plate assembly.
	Check valve obstructed.	Disassemble the wet end of the pump and manually dislodge obstruction in the check valve.
	Check valve and/or seat is worn or needs adjusting.	Inspect check valves and seats for wear and proper setting. Replace if necessary.
	Entrained gas or vapor lock in chamber(s).	Purge chambers through tapped chamber vent plugs. Purging the chambers of gas can be dangerous.
Product Leaking Through Exhaust	Diaphragm failure, or diaphragm plates loose.	Replace diaphragms, check for damage and ensure diaphragm plates are tight.
	Diaphragm stretched around center hole or bolt holes.	Check for excessive inlet pressure or gas pressure. Consult Chemical Resistance Chart for compatibility with products, cleaners, temperature limitations and lubrication.
Premature Diaphragm Failure	Cavitation.	Enlarge pipe diameter on suction side of pump.
	Excessive flooded suction pressure.	Move pump closer to product. Raise pump/place pump on top of tank to reduce inlet pressure. Install Back pressure device (Tech bulletin 41r). Add accumulation tank or pulsation dampener.
	Misapplication (chemical/physical incompatibility).	Consult Chemical Resistance Chart for compatibility with products, cleaners, temperature limitations and lubrication.
	Incorrect diaphragm plates or plates on backwards, installed incorrectly or worn.	Check Operating Manual to check for correct part and installation. Ensure outer plates have not been worn to a sharp edge.
Unbalanced Cycling	Excessive suction lift.	For lifts exceeding 20' of liquid, filling the chambers with liquid will prime the pump in most cases.
	Undersized suction line.	Meet or exceed pump connections.
	Pumped fluid in gas exhaust muffler.	Disassemble pump chambers. Inspect for diaphragm rupture or loose diaphragm plate assembly.
	Suction side gas leakage or gas in product.	Visually inspect all suction-side gaskets and pipe connections.
	Check valve obstructed.	Disassemble the wet end of the pump and manually dislodge obstruction in the check valve pocket.
	Check valve and/or seat is worn or needs adjusting.	Inspect check valves and seats for wear and proper setting. Replace if necessary.
	Entrained gas or vapor lock in chamber(s).	Purge chambers through tapped chamber vent plugs.

For additional troubleshooting tips contact After Sales Support at service.warrenrupp@idexcorp.com or 419-524-8388

Composite Repair Parts Drawing

3: EXP VIEW

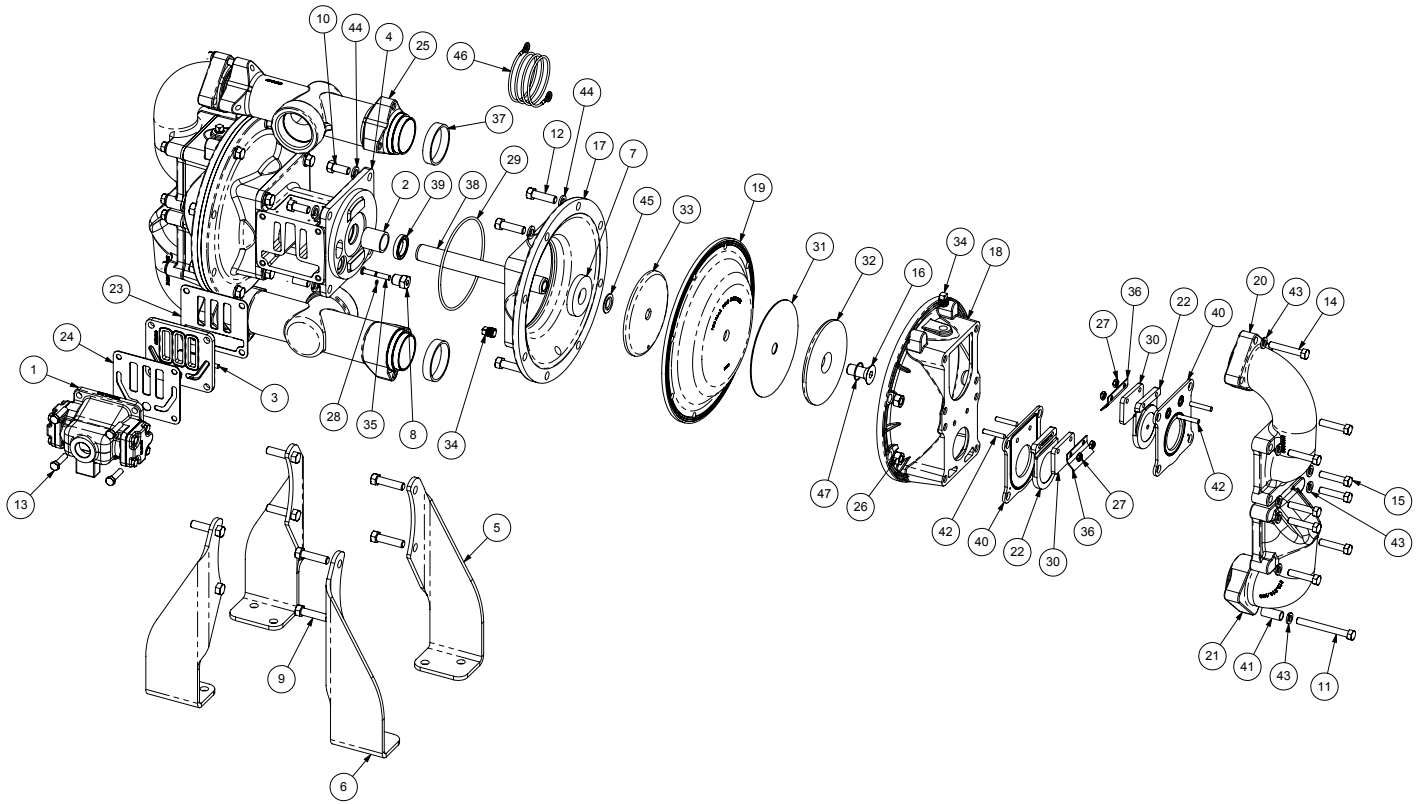

Service & Repair Kits

476.359.360

Nitrile Gas End Kit

Nitrile Seals, Bumpers, O-rings, and Gaskets, Retaining Rings, Plungers, Bushings Gas Valve Assembly with Nitrile O-rings Pilot Valve Assembly with O-rings

476.359.363

FKM Gas End Kit

FKM Seals, Bumpers and O-rings, Nitrile Gaskets, Retaining Rings, Plungers, Bushings Gas Valve Assembly with FKM O-rings Pilot Valve Assembly with FKM O-rings

476.360.360

Nitrile Gas End Wear Kit

Nitrile Seals, Bumpers, O-rings, and Gaskets, Retaining Rings, Plungers, Bushings

476.360.363

FKM Gas End Wear Kit

FKM Seals, Bumpers and O-rings, Nitrile Gaskets, Retaining Rings, Plungers, Bushings

476.270.360

Nitrile Wet End Kit

Diaphragms, Flap Valves, Hinge Pads, Wear Pads, Sealing Rings, and Stator-Seals

476.270.363

FKM Wet End Kit

Diaphragms, Flap Valves, Hinge Pads, Wear Pads, Sealing Rings, and Stator-Seals

Composite Repair Parts List

Item	Part Number	Description	Qty.	Item	Part Number	Description	Qty.
①	031.208.360	Gas Valve Assembly with Nitrile O-rings	1	③⑤	620.011.114	Actuator Plunger	2
	031.208.363	Gas Valve Assembly with FKM O-rings	1	36	670.005.110	Flap Valve Retainer	4
2	070.006.571	Rulon FCJ Sleeve Bearing	2	③⑦	675.013.360	Sealing Ring	4
③	095.073.002	Pilot Valve Assembly with Nitrile O-rings	1		675.013.363	Sealing Ring	4
	095.073.363	Pilot Valve Assembly with FKM O-rings	1	38	685.007.120	Diaphragm Rod	1
4	114.002.156	Intermediate Bracket	1	③⑨	720.004.360	U-Cup Seal	2
5	115.158.080	Leg Bracket	2		720.004.363	U-Cup Seal	2
6	115.159.080	Leg Bracket	2	40	722.070.360	Flap Valve Seat	4
⑦	132.002.360	Bumper	2		722.070.363	Flap Valve Seat	4
	132.002.363	Bumper	2	41	770.005.330	Spacer	2
⑧	135.016.506	Threaded Bushing	2	42	807.018.110	Stud 1/4-20UNC	8
9	170.023.330	Hex Cap Screw 7/16-14UNC x 1.75 Long	8	43	900.005.330	Lock Washer 3/8	20
10	170.024.330	Hex Cap Screw 7/16-14UNC x 1.00 Long	8	44	900.006.330	Lock Washer 7/16	16
11	170.026.330	Hex Cap Screw 3/8-16UNC x 3.50 Long	2	45	902.003.000	Sealing Washer	2
12	170.035.330	Hex Cap Screw 7/16-14UNC x 1.50 Long	8	46	920.025.000	Grounding Cable	1
13	170.045.330	Hex Cap Screw 5/16-18UNC x 1.25 Long	4	④⑦	560.046.360	O-ring (use with Stainless Steel Outer Plates and Nitrile-equipped wet end components)	2
14	170.052.330	Hex Cap Screw 3/8-16UNC x 2.50 Long	2		560.070.610	O-ring (use with Stainless Steel Outer Plates and FKM-equipped wet end components)	2
15	170.061.330	Hex Cap Screw 3/8-16UNC x 1.75 Long	16				
16	171.002.110	Socket Head Cap Screw 5/8-11UNC x 1.50 Long	2				
	171.002.330	Socket Head Cap Screw 5/8-11UNC x 1.50 Long	2				
17	196.001.157	Inner Chamber	2				
18	196.002.110	Outer Chamber	2				
	196.002.157	Outer Chamber	2				
①⑨	286.007.360	Diaphragm	2				
	286.007.363	Diaphragm	2				
20	312.012.110	Suction Elbow	2				
	312.012.156	Suction Elbow	2				
21	312.013.110	Discharge Elbow	2				
	312.013.156	Discharge Elbow	2				
②②	338.005.360	Flap Valve	4				
	338.005.363	Flap Valve	4				
②③	360.041.379	Gasket	1				
②④	360.048.360	Gasket	1				
25	518.001.110	Manifold	2				
	518.001.157	Manifold	2				
26	545.007.110	Hex Nut 7/16-14UNC 2B	8				
	545.007.330	Hex Nut 7/16-14UNC 2B	8				
27	547.002.110	Stop Nut 1/4-20UNC 2B	8				
②⑧	560.001.360	O-ring	2				
	560.001.363	O-ring	2				
②⑨	560.022.360	O-ring	2				
	560.022.363	O-ring	2				
③⑩	570.001.360	Hinge Pad	4				
	570.001.363	Hinge Pad	4				
③①	570.009.360	Wear Pad	2				
	570.009.363	Wear Pad	2				
32	612.047.330	Outer Diaphragm Plate	2				
	612.096.110	Outer Diaphragm Plate (Stainless Steel ONLY)	2				
33	612.008.330	Inner Diaphragm Plate	2				
34	618.003.330	Pipe Plug 1/4 NPT	4				
	618.003.330	Pipe Plug 1/4 NPT (Stainless Steel ONLY)	2				
	618.003.110	Pipe Plug 1/4 NPT (Stainless Steel ONLY)	2				

LEGEND:

- = Items contained within Gas End Kits
- = Items contained within Wet End Kits

Note: Kits contain components specific to the material codes.

Material Codes - The Last 3 Digits of Part Number

000.....Assembly, sub-assembly; and some purchased items	364.....EPDM Rubber Color coded: BLUE
010.....Cast Iron	365.....Neoprene Rubber Color coded: GREEN
015.....Ductile Iron	366.....Food Grade Nitrile
020.....Ferritic Malleable Iron	368.....Food Grade EPDM
080.....Carbon Steel, AISI B-1112	371.....Philthane (Tuftane)
110.....Alloy Type 316 Stainless Steel	374.....Carboxylated Nitrile
111.....Alloy Type 316 Stainless Steel (Electro Polished)	375.....Fluorinated Nitrile
112.....Alloy C	378.....High Density Polypropylene
113.....Alloy Type 316 Stainless Steel (Hand Polished)	379.....Conductive Nitrile
114.....303 Stainless Steel	408.....Cork and Neoprene
115.....302/304 Stainless Steel	425.....Compressed Fibre
117.....440-C Stainless Steel (Martensitic)	426.....Blue Gard
120.....416 Stainless Steel (Wrought Martensitic)	440.....Vegetable Fibre
148.....Hardcoat Anodized Aluminum	500.....Delrin® 500
150.....6061-T6 Aluminum	502.....Conductive Acetal, ESD-800
152.....2024-T4 Aluminum (2023-T351)	503.....Conductive Acetal, Glass-Filled
155.....356-T6 Aluminum	506.....Delrin® 150
156.....356-T6 Aluminum	520.....Injection Molded PVDF Natural color
157.....Die Cast Aluminum Alloy #380	540.....Nylon
158.....Aluminum Alloy SR-319	542.....Nylon
162.....Brass, Yellow, Screw Machine Stock	544.....Nylon Injection Molded
165.....Cast Bronze, 85-5-5-5	550.....Polyethylene
166.....Bronze, SAE 660	551.....Glass Filled Polypropylene
170.....Bronze, Bearing Type, Oil Impregnated	552.....Unfilled Polypropylene
180.....Copper Alloy	555.....Polyvinyl Chloride
305.....Carbon Steel, Black Epoxy Coated	556.....Black Vinyl
306.....Carbon Steel, Black PTFE Coated	558.....Conductive HDPE
307.....Aluminum, Black Epoxy Coated	570.....Rulon II®
308.....Stainless Steel, Black PTFE Coated	580.....Ryton®
309.....Aluminum, Black PTFE Coated	600.....PTFE (virgin material) Tetrafluorocarbon (TFE)
313.....Aluminum, White Epoxy Coated	603.....Blue Gylon®
330.....Zinc Plated Steel	604.....PTFE
332.....Aluminum, Electroless Nickel Plated	606.....PTFE
333.....Carbon Steel, Electroless Nickel Plated	607.....Envelon
335.....Galvanized Steel	608.....Conductive PTFE
337.....Silver Plated Steel	610.....PTFE Encapsulated Silicon
351.....Food Grade Santoprene®	611.....PTFE Encapsulated FKM
353.....Geolast; Color: Black	632.....Neoprene/Hytrel®
354.....Injection Molded #203-40 Santoprene® Duro 40D +/-5; Color: RED	633.....FKM/PTFE
356.....Hytrel®	634.....EPDM/PTFE
357.....Injection Molded Polyurethane	635.....Neoprene/PTFE
358.....Urethane Rubber (Some Applications) (Compression Mold)	637.....PTFE, FKM/PTFE
359.....Urethane Rubber	638.....PTFE, Hytrel®/PTFE
360.....Nitrile Rubber Color coded: RED	639.....Nitrile/TFE
363.....FKM (Fluorocarbon) Color coded: YELLOW	643.....Santoprene®/EPDM
	644.....Santoprene®/PTFE
	656.....Santoprene® Diaphragm and Check Balls/EPDM Seats
	661.....EPDM/Santoprene®
	666.....FDA Nitrile Diaphragm, PTFE Overlay, Balls, and Seals
	668.....PTFE, FDA Santoprene®/PTFE

- Delrin and Hytrel are registered tradenames of E.I. DuPont.
- Nylatron is a registered tradename of Polymer Corp.
- Gylon is a registered tradename of Garlock, Inc.
- Santoprene is a registered tradename of Exxon Mobil Corp.
- Rulon II is a registered tradename of Dixon Industries Corp.
- Ryton is a registered tradename of Phillips Chemical Co.
- Valox is a registered tradename of General Electric Co.

RECYCLING

Many components of SANDPIPER® AODD pumps are made of recyclable materials. We encourage pump users to recycle worn out parts and pumps whenever possible, after any hazardous pumped fluids are thoroughly flushed.

Gas Distribution Valve Assembly

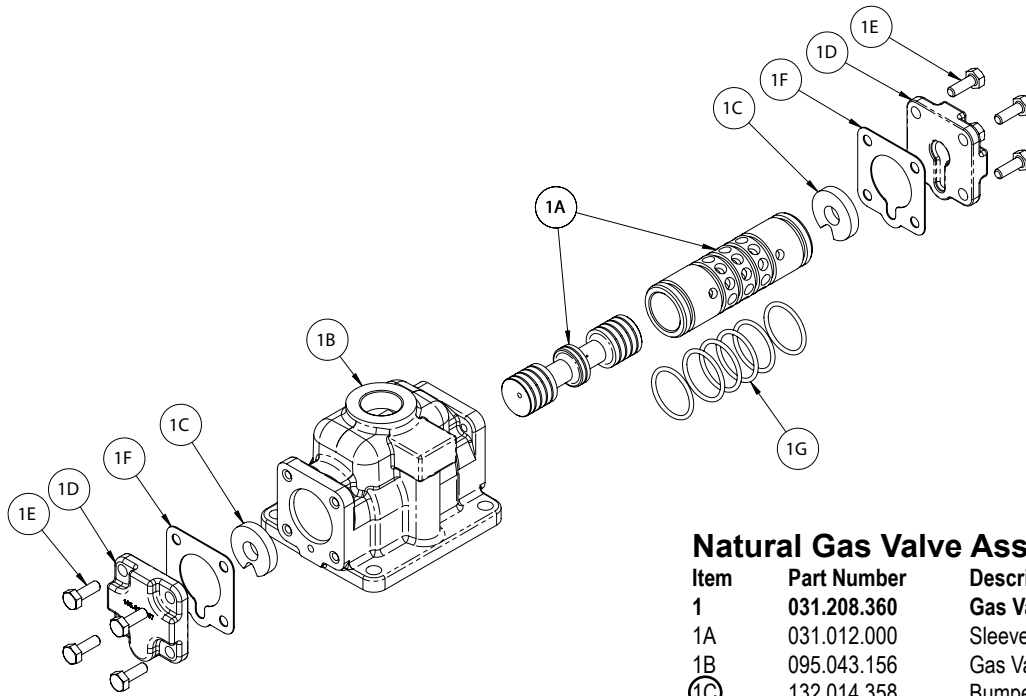

Natural Gas Valve Assembly with Nitrile O-rings

Item	Part Number	Description	Qty
1	031.208.360	Gas Valve Assembly	1
1A	031.012.000	Sleeve and Spool Set	1
1B	095.043.156	Gas Valve Body	1
1C	132.014.358	Bumper	2
1D	165.011.157	End Cap	2
1E	170.032.330	Hex Cap Screw 1/4-20UNC x .75 Long	8
1F	360.010.360	Gasket	2
1G	560.020.360	O-Ring	6

Natural Gas Valve Assembly with FKM O-rings

Item	Part Number	Description	Quantity
1	031.208.363	Gas Valve Assembly	1
1A	031.012.000	Sleeve and Spool Set	1
1B	095.043.156	Gas Valve Body	1
1C	132.014.358	Bumper	2
1D	165.011.157	End Cap	2
1E	170.032.330	Hex Cap Screw 1/4-20UNC x .75 Long	8
1F	360.010.360	Gasket	2
1G	560.020.363	O-Ring	6

LEGEND:

○ = Items contained within Gas End Kits

IMPORTANT



Read these instructions completely, before installation and start-up. It is the responsibility of the purchaser to retain this manual for reference. Failure to comply with the recommendations stated in this manual will damage the pump, and void factory warranty.



ATEX Compliant

Gas Distribution Valve Servicing

Step 1: Remove cap screws (1-E).

Step 2: Remove end cap (1-D) and bumper (1-C).

Step 3: Remove spool part of (1-A) (caution: do not scratch).

Step 4: Press sleeve (1-A) from body (1-B).

Step 5: Inspect O-Ring (1-G) and replace if necessary.

Step 6: Lightly lubricate O-Rings (1).

Step 7: Press sleeve (1-A) into body (1-B).

Step 8: Reassemble in reverse order, starting with step 3.

Note: Sleeve and spool (1-B) set is match ground to a specified clearance sleeve and spools (1-B) cannot be interchanged.

Pilot Valve Assembly

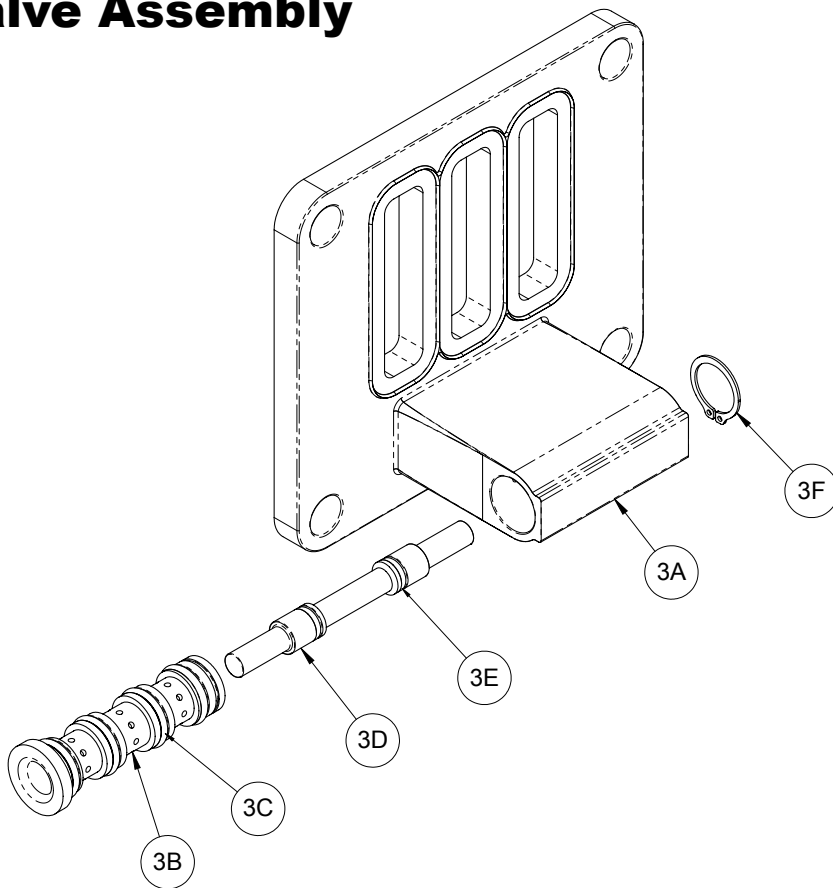

4: AIR END

Pilot Valve Servicing

With Pilot Valve removed from pump.

Step 1: Remove snap ring (3-F).

Step 2: Remove sleeve (3-B), inspect O-Rings (3-C), replace if required.

Step 3: Remove spool (3-D) from sleeve (3-B), inspect O-Rings (3-E), replace if required.

Step 4: Lightly lubricate O-Rings (3-C) and (3-E).

Reassemble in reverse order.

Pilot Valve Assembly with Nitrile O-rings

Item	Part Number	Description	Qty
3	095.073.002	Gas Pilot Valve Assembly	1
3A	095.070.558	Gas Pilot Valve Body	1
3B	755.025.001	Pilot Valve Sleeve Assembly	1
3C	560.033.360	O-Ring	4
3D	775.026.000	Pilot Valve Spool Assembly	1
3E	560.023.360	O-Ring	2
3F	675.037.080	Retaining Ring	1

Pilot Valve Assembly with FKM O-rings

Item	Part Number	Description	Qty
3	095.073.363	Gas Pilot Valve Assembly	1
3A	095.070.558	Gas Pilot Valve Body	1
3B	755.025.363	Pilot Valve Sleeve Assembly	1
3C	560.033.363	O-Ring	4
3D	775.026.363	Pilot Valve Spool Assembly	1
3E	560.023.363	O-Ring	2
3F	675.037.080	Retaining Ring	1

LEGEND:

○ = Items contained within Gas End Kits

Diaphragm Servicing

Step 1: With manifolds and outer chambers removed, remove diaphragm assemblies from diaphragm rod. **DO NOT** use a pipe wrench or similar tool to remove assembly from rod. Flaws in the rod surface may damage bearings and seal. Soft jaws in a vise are recommended to prevent diaphragm rod damage.

Step 1.A: NOTE: Not all inner diaphragm plates are threaded. Some models utilize a through hole in the inner diaphragm plate. If required to separate diaphragm assembly, place assembly in a vise, gripping on the exterior cast diameter of the inner plate. Turn the outer plate clockwise to separate the assembly.

Always inspect diaphragms for wear cracks or chemical attack. Inspect inner and outer plates for deformities, rust scale and wear. Inspect intermediate bearings for elongation and wear. Inspect diaphragm rod for wear or marks.

Clean or repair if appropriate. Replace as required.

Step 2: Reassembly: There are two different types of diaphragm plate assemblies utilized throughout the Sandpiper product line: Outer plate with a threaded stud, diaphragm, and a threaded inner plate.

Outer plate with a threaded stud, diaphragm, and an inner plate with through hole. Secure threaded inner plate in a vise. Ensure that the plates are being installed with the outer radius against the diaphragm.

Step 3: Lightly lubricate, with a compatible material, the inner faces of both outer and inner diaphragm plates when using on non Overlay diaphragms (For EPDM water is recommended). No lubrication is required.

Step 4: Push the threaded outer diaphragm plate through the center hole of the diaphragm.

Note: Most diaphragms are installed with the natural bulge out towards the fluid side. S05, S07, and S10 non-metallic units are installed with the natural bulge in towards the gas side.

Step 5: Thread or place, outer plate stud into the inner plate. For threaded inner plates, use a torque wrench to tighten the assembly together. Torque values are called out on the exploded view.

Repeat procedure for second side assembly. Allow a minimum of 15 minutes to elapse after torquing, then re-torque the assembly to compensate for stress relaxation in the clamped assembly.

Step 6: Thread one assembly onto the diaphragm rod with sealing washer (when used) and bumper.

Step 7: Install diaphragm rod assembly into pump and secure by installing the outer chamber in place and tightening the capscrews.

Step 8: On opposite side of pump, thread the remaining assembly onto the diaphragm rod. Using a torque wrench, tighten the assembly to the diaphragm rod. Align diaphragm through bolt holes, always going forward past the recommended torque. Torque values are called out on the exploded view. **NEVER** reverse to align holes, if alignment cannot be achieved without damage to diaphragm, loosen complete assemblies, rotate diaphragm and reassemble as described above.

IMPORTANT



Read these instructions completely, before installation and start-up. It is the responsibility of the purchaser to retain this manual for reference. Failure to comply with the recommendations stated in this manual will damage the pump, and void factory warranty.

PUMPING HAZARDOUS LIQUIDS

When a diaphragm fails, the pumped liquid or fumes enter the natural gas end of the pump. Fumes are exhausted into the surrounding environment. When pumping hazardous or toxic materials, the exhaust gas must be piped to an appropriate area for safe disposal. See illustration #1 at right.

This pump can be submerged if the pump materials of construction are compatible with the liquid being pumped. The natural gas exhaust must be piped above the liquid level. See illustration #2 at right. Piping used for the gas exhaust must not be smaller than 1" (2.54 cm) diameter. Reducing the pipe size will restrict natural gas flow and reduce pump performance. When the pumped product source is at a higher level than the pump (flooded suction condition), pipe the exhaust gas higher than the product source to prevent siphoning spills. See illustration #3 at right.

IMPORTANT INSTALLATION NOTE: The manufacturer recommends installing a flexible conductive hose or connection between the pump and any rigid plumbing. This reduces stresses on the molded threads of the natural gas exhaust port. Failure to do so may result in damage to the natural gas distribution valve body.

Any piping or hose connected to the pump's natural gas exhaust port must be conductive and physically supported. Failure to support these connections could also result in damage to the valve body.

If a high pressure gas spike is possible through the exhaust line, a pressure regulator is required in the exhaust piping.

NATURAL GAS EXHAUST ILLUSTRATION

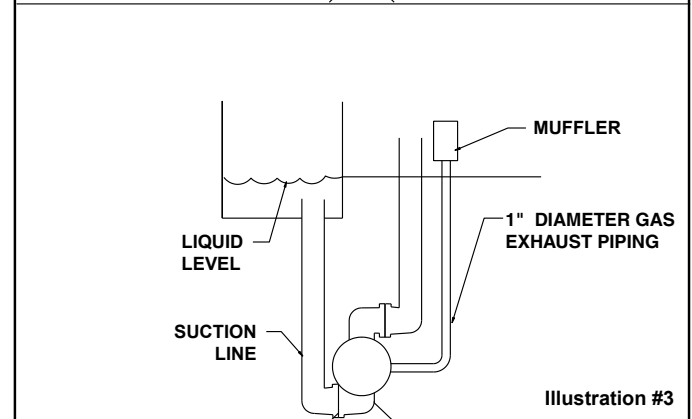
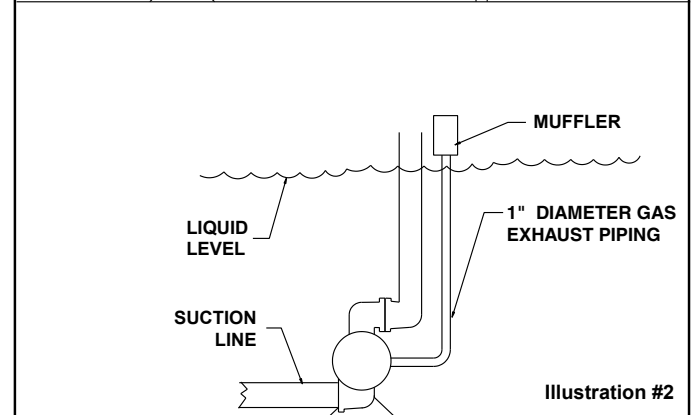
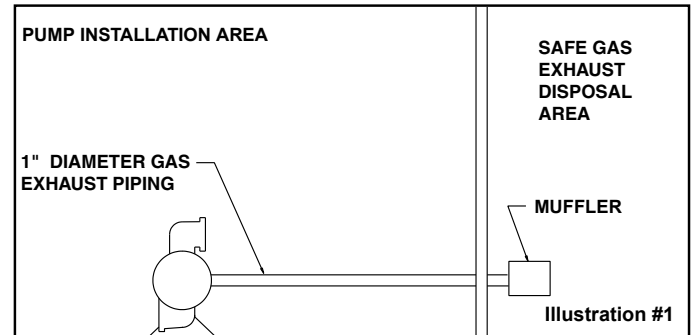

5: WET END

⚠ WARNING

Natural gas exhaust is to be vented to low pressure safe location using conductive Nitrile rubber hose or metal piping in accordance with local fire and environmental codes, or an industry or nationally recognized code having jurisdiction over specific installations, and/or CAN/CGA B149, Installation Codes.

5 - YEAR Limited Product Warranty

Warren Rupp, Inc. ("Warren Rupp") warrants to the original end-use purchaser that no product sold by Warren Rupp that bears a Warren Rupp brand shall fail under normal use and service due to a defect in material or workmanship within five years from the date of shipment from Warren Rupp's factory. Warren Rupp brands include Warren Rupp®, SANDPIPER®, SANDPIPER Signature Series™, MARATHON®, Porta-Pump®, SludgeMaster™ and Tranquilizer®.

The use of non-OEM replacement parts will void (or negate) agency certifications, including CE, ATEX, CSA, 3A and EC1935 compliance (Food Contact Materials). Warren Rupp, Inc. cannot ensure nor warrant non-OEM parts to meet the stringent requirements of the certifying agencies.

~ See sandpiperpump.com/content/warranty-certifications for complete warranty, including terms and conditions, limitations and exclusions. ~

**WARREN
RUPP, INC.**

Declaration of Conformity

Manufacturer: Warren Rupp, Inc., 800 N. Main Street
Mansfield, Ohio, 44902 USA

Certifies that Air-Operated Double Diaphragm Pump Series: HDB, HDF, M Non-Metallic, S Non-Metallic, M Metallic, S Metallic, T Series, G Series, U Series, EH and SH High Pressure, RS Series, W Series, SMA and SPA Submersibles, and Tranquilizer® Surge Suppressors comply with the European Community Directive 2006/42/EC on Machinery, according to Annex VIII. This product has used Harmonized Standard EN809:1998+A1:2009, Pumps and Pump Units for Liquids - Common Safety Requirements, to verify conformance.

Signature of authorized person

October 20, 2005
Date of issue

Authorised Representative:
IDEX Pump Technologies
R79 Shannon Industrial Estate
Shannon, Co. Clare, Ireland

Director of Engineering
Title

February 27, 2017
Date of revision

Attn: Barry McMahon

IDEX

Revision Level: F

CE

WARREN RUPP, INC.

EC / EU Declaration of Conformity

The objective of the declaration described is in conformity with the relevant Union harmonisation legislation: Directive 94/9/EC (until April 19, 2016) and Directive 2014/34/EU (from April 20, 2016).

Manufacturer:

Warren Rupp, Inc.
A Unit of IDEX Corporation
800 North Main Street
P.O. Box 1568
Mansfield, OH 44902 USA

Applicable Standard:

EN13463-1: 2001
EN13463-5: 2003
EN60079-25: 2004

Harmonised Standard:

EN13463-1: 2009
EN13463-5: 2011
EN60079-25:2010

The harmonised standards have been compared to the applicable standards used for certification purposes and no changes in the state of the art technical knowledge apply to the listed equipment.

AODD Pumps and Surge Suppressors

Technical File No.: 203104000-1410/MER

AODD (Air-Operated Double Diaphragm) Pumps

EC Type Examination Certificate No. Pumps: KEMA 09ATEX0071 X

DEKRA Certification B.V. (0344)
Meander 1051
6825 MJ Arnhem
The Netherlands

Hazardous Locations Applied:

I M1 c	II 1 G c T5
II 2 G Ex ia c IIC T5	II 1 D c T100°C
II 2 D Ex c iaD 20 IP67 T100°C	II 2 G c T5
II 2 G Eex m c II T5	II 2 D c T100°C
II 2 D c IP65 T100°C	II 2 G c IIB T5

SANDPIPER®
A WARREN RUPP, INC. BRAND

Tranquilizer®

DATE/APPROVAL/TITLE:
18 March 2016

David Roseberry
David Roseberry, Director of Engineering

IDEX